

EXISTING BRICK CURB OPPOSITE SIDE OF CONCRETE TRANSITION CURB

CONCRETE TRANSITION CURB SHAPE TO MATCH PROFILE AND DIMENSIONS OF ADJACENT EXISTING BRICK CURB CREATING A FLUSH CONDITION AND SMOOTH TRANSITION FROM EXISTING BRICK CURB TO CONCRETE APRON

BRICK GUTTER

CEMENT MORTAR BEDDING

CONCRETE DRIVEWAY APRON

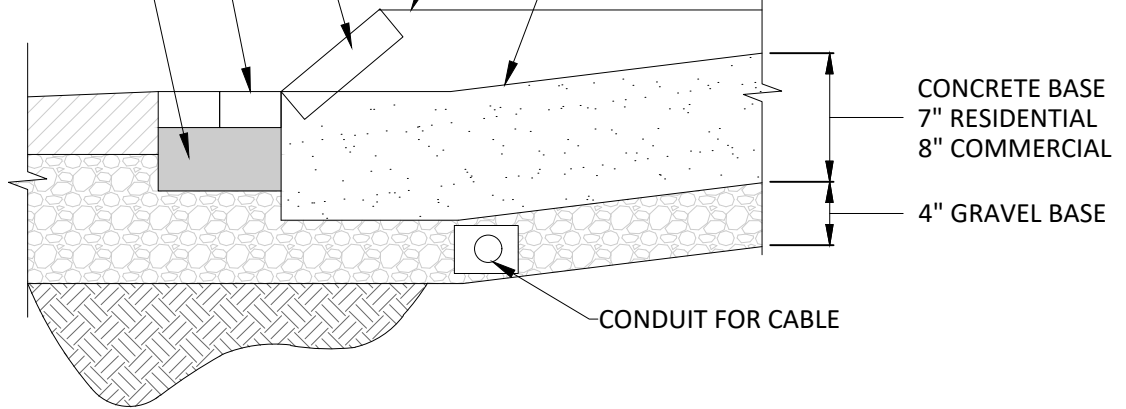

SECTION A-A

PIPE TO HAVE BRICK IMMEDIATELY ADJACENT ON EITHER SIDE OR ENCASED IN CONCRETE WITH 1-2" MAX ON EITHER SIDE. NO BRICK ON TOP.

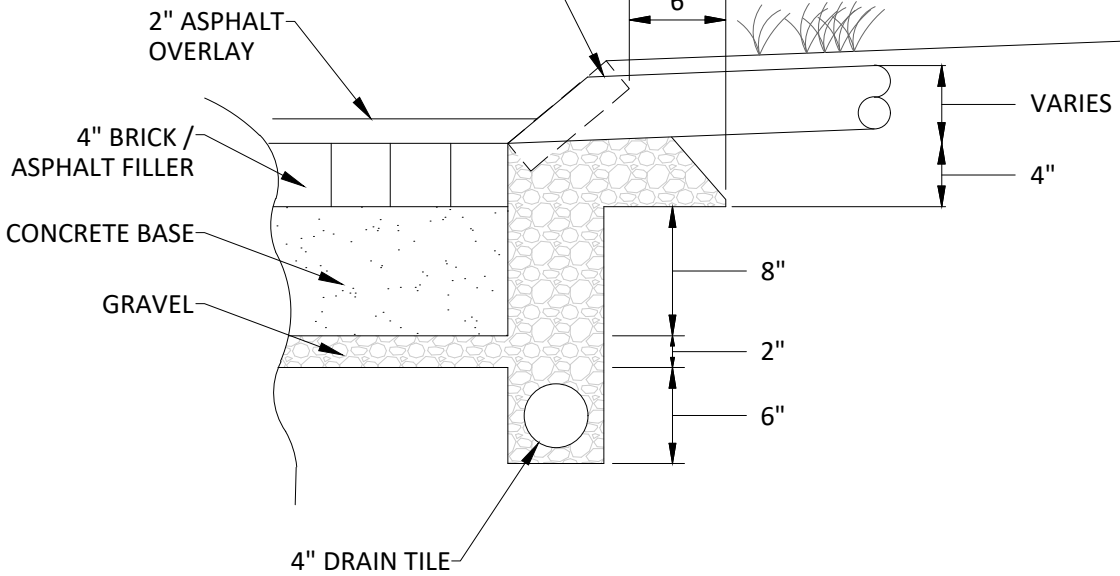

SECTION B-B

DATE: 11/18/20

**STANDARD DRIVEWAY  
APPROACH W/ BRICK CURB**

STANDARD CONSTRUCTION DRAWING

CITY OF BEXLEY, OHIO

BEX-ST-04.1