

Ordinance 12 - 24

By: Sam Marcellino

An Ordinance authorizing the Mayor and Auditor to sign a Consent and Hold Harmless Agreement on behalf of the City of Bexley with the property owner 394 South Columbia (Parcel No. 020-002008), regarding improvements made upon and within the City owned right-of-way between the sidewalk and the property line.

BE IT ORDAINED BY THE COUNCIL OF THE CITY OF BEXLEY, OHIO:

Section 1.

That the property owner at 394 South Columbia Avenue (Parcel No. 020-002008) is permitted to install three, 40" decorative stone decorative columns in the Right-of-Way between the sidewalk and the property line as described above and in Exhibit "A" attached hereto and incorporated herein by reference.

Section 2.

That the Mayor and Auditor are authorized to enter into a Consent and Hold Harmless Agreement with the property owners, in form and substance satisfactory to the City Attorney, authorizing the encroachments as proposed in accordance with the submitted request on the condition that the property owners assume all responsibility for damage, loss and injury arising out of the location of said building features, including any additional cost to the City of Bexley incurred in connection with its use of right-of-way occasioned by the location of the improvements.

Section 3.

That this Ordinance shall take effect and be in force from and after the earliest period allowed by law.

Passed: May 14, 2024

Attest: 
Matt McPeek, Clerk of Council

Monique Lampke, President of Council

Ben Kessler, Mayor

First Reading: April 9, 2024
Second Reading: April 23, 2024
Third Reading: May 14, 2024

NOTE: MASON TO PROVIDE FOOTING
 DESIGN: 20" CMU BLOCK CORE ON
 3'X3'X12" CIC FOOTING AT 36" DEPTH

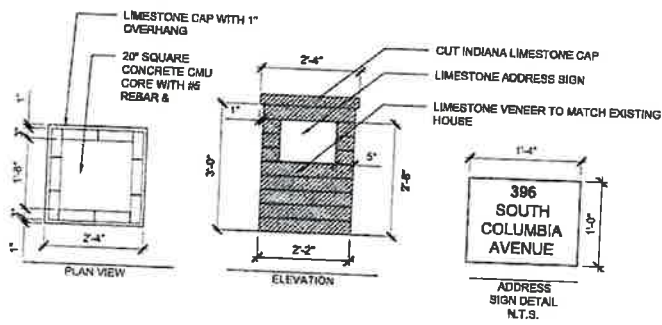

C **STONE ENTRY COLUMNS**
 SCALE: 1/2" = 1'-0"

394 S. Columbia

