

**ORDINANCE NO. 30 -17**

By: Steve Keyes

**An Ordinance authorizing the Service Director to sign a Consent and Hold Harmless Agreement on behalf of the City of Bexley with the property owner at 2424 E. Main Street, for Kittie's, located in Suite 150, and previously known as 2418 E. Main Street, granting a right of encroachment regarding improvements made upon and within the City owned street right-of-way adjacent to Cassady Avenue, and a seasonal enclosure, located in the City owned street right-of-way adjacent to E. Main Street;**

WHEREAS, a fence, patio, awnings, and seasonal enclosure, located in the City right-of-way on the east side of the building are approved and can remain in place as shown in Exhibit "A" attached (26'4" wide x 92" deep) and a seasonal enclosure, located in the City right-of-way on the south side of the building are approved and can be located as shown in Exhibit "B" attached (48" x 132"); and

WHEREAS, the owner of 2424 E. Main, Gramercy Partners LLC, constructed a patio and fence over a portion of the public walk adjacent to Cassady Avenue; and

WHEREAS, fencing, raised patios and seasonal enclosures are not permitted in the public right-of-way unless approved and a Consent and Hold Harmless Agreement are executed; and

WHEREAS, the Service Director has the authority to grant a public right-of-way certificate in accordance with Chapter 1028 of the City codified ordinances subject to conditions set by City Council that it deems to be reasonable;

NOW THEREFORE, BE IT ORDAINED BY THE COUNCIL OF THE CITY OF BEXLEY, OHIO:

Section 1.

That the Service Director is authorized to grant a public right-of-way for the patio, fence, awnings and seasonal enclosures within the public right-of-way at 2424 E. Main Street subject to the owner signing a Consent and Hold Harmless Agreement and subject to all applicable provisions of Chapter 1028 of the City of Bexley codified ordinances.

Ordinance 30-17



Section 2.

That this Ordinance shall take effect and be in force from and after the earliest period allowed by law.

Passed: Dec 5, 2017



Tim Madison, President of Council

Attest: Bill Harvey  
Bill Harvey, Clerk of Council

Approved: Dec 5, 2017



Ben Kessler, Mayor

First Reading: 11-14-17  
Second Reading: 11-28-17  
Third Reading: 12-5-17



**SIDE VESTIBULE PLAN VIEW**

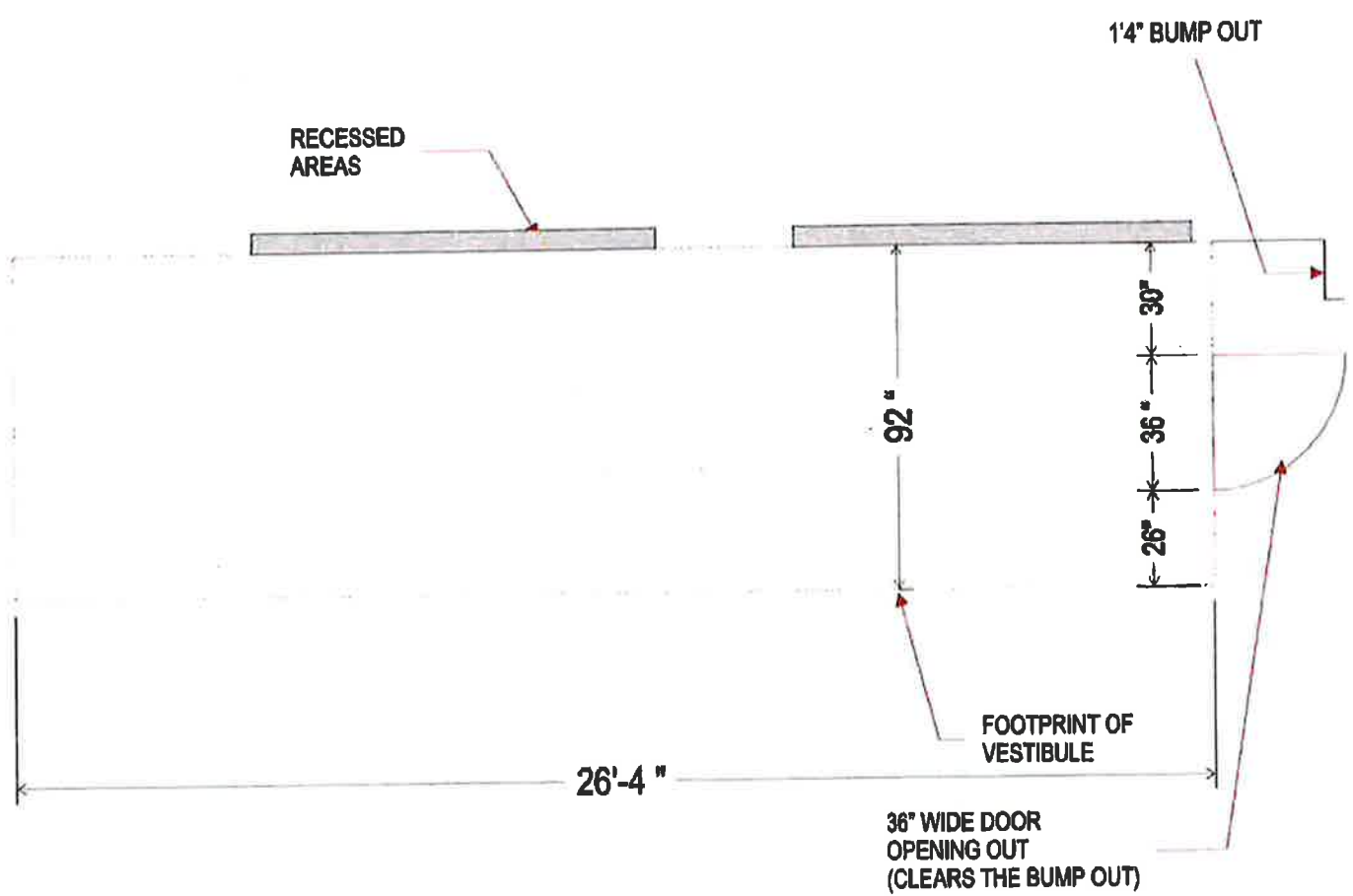

Exhibit "A"

SIDE VESTIBULE

LEFT VESTIBULE  
HIPPED ROOF ON LEFT



COLUMBUS AWNING  
COMPANY  
225C East Broadway  
Westerville, Ohio 43081

Grammercy  
Vestibule

Exhibit "A"

4' PROJECTION AWNING LAYOUT

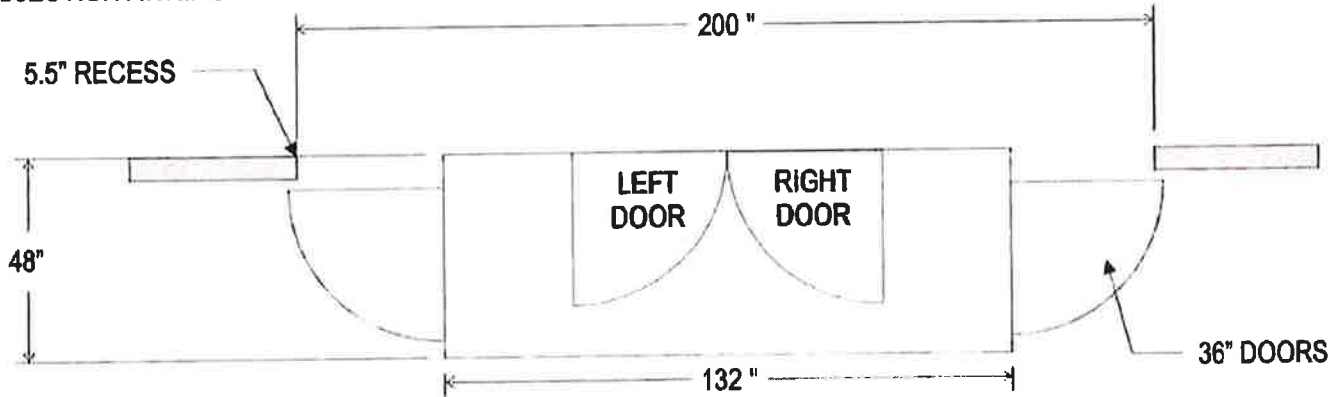

FASTENING SYSTEM FOR REMOVABLE PANELS

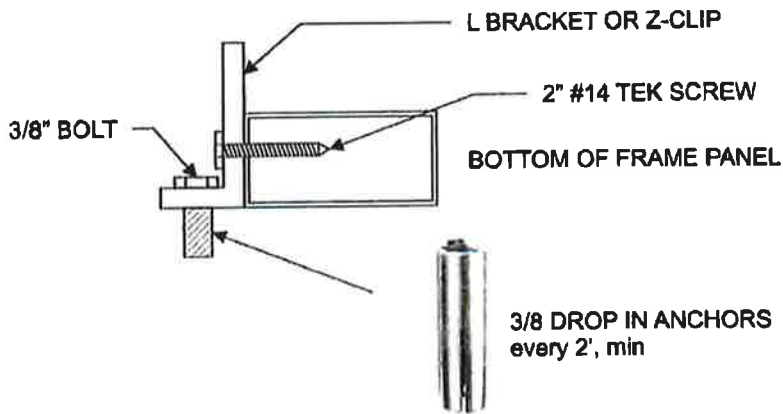

COLUMBUS AWNING  
COMPANY  
225C East Broadway  
Westerville, Ohio 43081

Grammercy  
Vestibule

Exhibit "B"

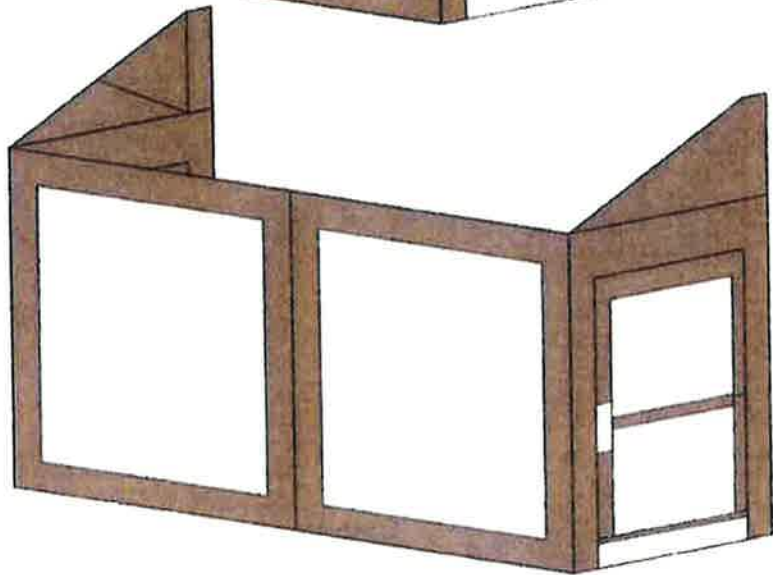
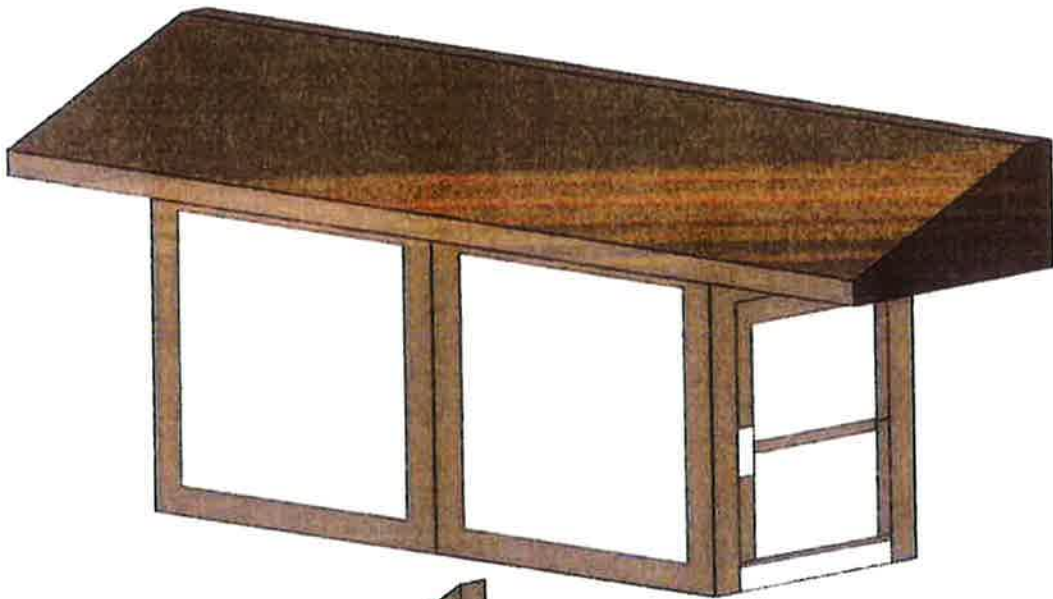
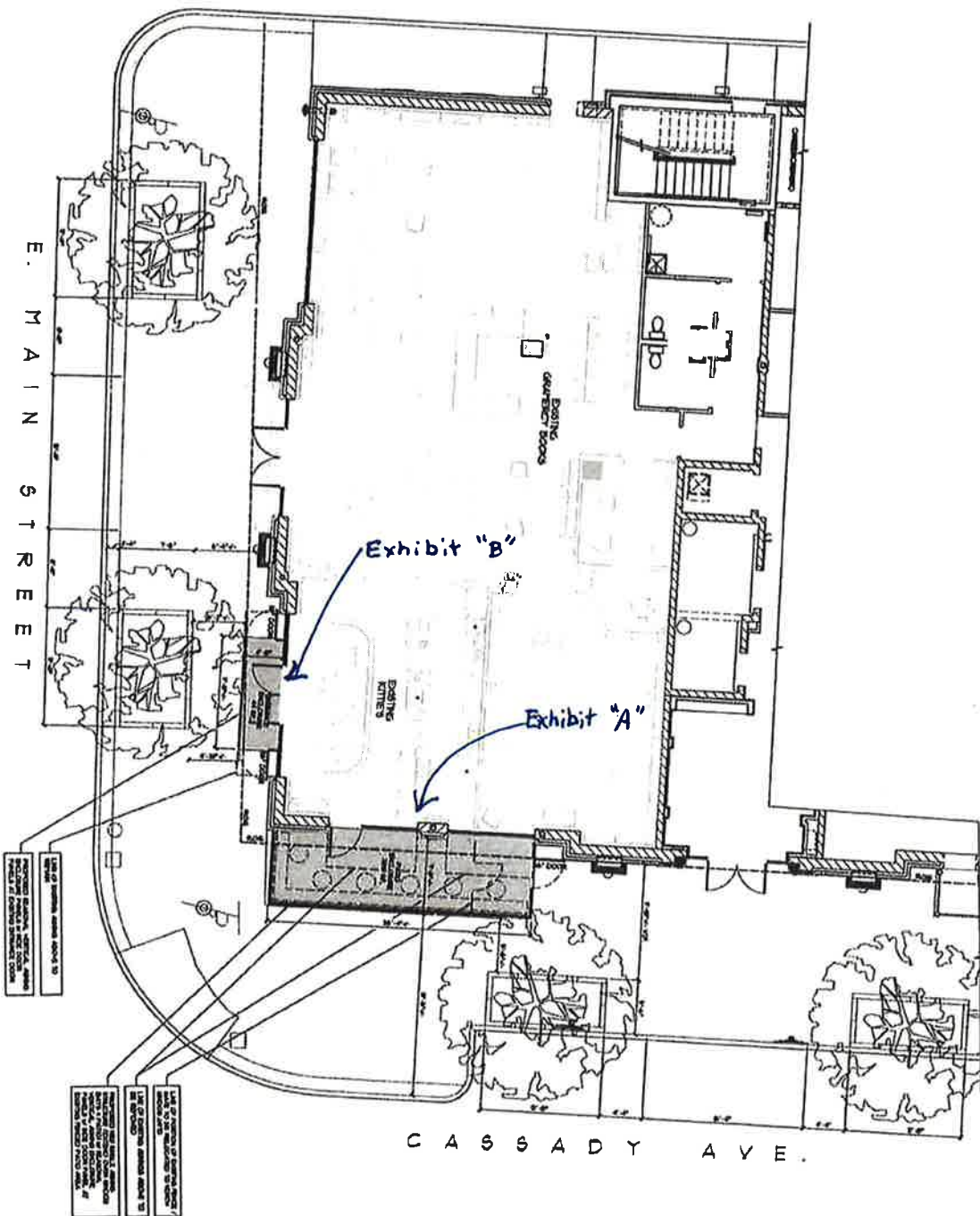

Exhibit "B"



Ⓐ PARTIAL SIDEWALK PLAN  
 02/17/98



1. THE SIDEWALK SHALL BE CONCRETE WITH A FINISH TO MATCH THE ADJACENT SIDEWALKS.

2. THE SIDEWALK SHALL BE 4' WIDE MINIMUM.

3. THE SIDEWALK SHALL BE 1/2" BELOW THE FINISH GRADE OF THE ADJACENT SIDEWALKS.

4. THE SIDEWALK SHALL BE 1/2" BELOW THE FINISH GRADE OF THE ADJACENT SIDEWALKS.

**THE GARMERY - KITTIE'S**  
 2418 E. Main Street  
 Bexley, Ohio 43209

FOR AND ASSOCIATES  
 ARCHITECTS  
 1200 Park Street  
 Columbus, Ohio 43206  
 614.261.1234

NO.	DATE	DESCRIPTION
1	02/17/98	ISSUED FOR PERMITS
2		
3		
4		
5		
6		
7		
8		
9		
10		
11		
12		
13		
14		
15		
16		
17		
18		
19		
20		
21		
22		
23		
24		
25		
26		
27		
28		
29		
30		
31		
32		
33		
34		
35		
36		
37		
38		
39		
40		
41		
42		
43		
44		
45		
46		
47		
48		
49		
50		
51		
52		
53		
54		
55		
56		
57		
58		
59		
60		
61		
62		
63		
64		
65		
66		
67		
68		
69		
70		
71		
72		
73		
74		
75		
76		
77		
78		
79		
80		
81		
82		
83		
84		
85		
86		
87		
88		
89		
90		
91		
92		
93		
94		
95		
96		
97		
98		
99		
100		

SD-111  
 THE GARMERY

