



CITY  
OF  
BEXLEY

DESIGN GUIDELINES  
AND  
STANDARDS



PRESENTED BY:  
THE ARCHITECTURAL  
REVIEW BOARD



Adopted by Bexley City Council  
24 January 2023



# FOREWORD

by Karen Bokor

For over two decades, the City of Bexley has continually advanced the goal of articulating a clear, workable, and interactive document that both describes Bexley's historic and beautiful neighborhoods and provides guidelines to enhance and preserve Bexley's architectural character. For residents, city staff, and board members this document provides an educational tool, a "guided tour", of the many styles and features of Bexley's architecture and a walk through of the design process.

There is no one author to this document. As Design Consultant to the City of Bexley, I have worked closely with many contributors over the years in the development of this document. In specific, William Heyer has been a critical contributor, and his expertise in classical language of architecture, beautiful example renderings, and commentary has been invaluable. Lawrence Helman, with his depth of knowledge of Bexley's history and neighborhood development, provided a historical understanding and context for the use of the guidelines. Kathy Rose, City of Bexley Zoning Officer, and her incomparable knowledge of the Bexley's zoning, history and institutional memory. The support and encouragement of Architectural Review Board members, city staff, and Mayor Kessler has been greatly appreciated as well.

Architecture has its own language, terms and process. It is important to understand these elements to then understand how and why guidelines can be used effectively in the planning and design of renovations, additions, or new construction. Bexley does not have a singular or preferred architecture, and each and every project is different. A major goal of the guidelines is to help inform residents about the elements of design and to advance and enhance visual thinking skills to create successful projects that thoughtfully contribute to the beauty of Bexley.

Understanding the language and terminology will make all the difference in how much you get out of the process of designing, renovating or building your home. It should also change the way you look at the built world outside of your own project and open your eyes to the importance and beauty of "place". The ultimate goal of these guidelines is to advance and enhance visual thinking skills by providing a formal look at the existing architecture and

We all encounter and interact with architecture. Much thought and hard work goes into the creation of spaces we use every day, and whether you are enjoying the environment or embarking on a building project of your own, we hope this document will enrich your experience in Bexley!

*Karen Bokor*

# DESIGN STANDARDS AND GUIDELINES

“Like any language, [architecture] has a vocabulary (the building elements such as windows, doors, and eaves) and grammar (the rules that we use to put the elements together). Designing a building without understanding these rules is like forming a sentence without understanding syntax. Without the foundation of basic knowledge, the results can be garbled, sometimes beyond recognition.”

- Marianne Cusato

Design standards and guidelines are sets of recommendations towards good practice in design. They are intended to provide clear instructions to, owners, designers, and developers on how to adopt specific principles.

## **DESIGN STANDARDS**

are widely applicable principles and considerations.  
Standards are the foundation for good design.

## **DESIGN GUIDELINES**

tell us how to apply standards.  
Guidelines are recommendations that provide instructions on how to convert standards into design.

# TABLE OF CONTENTS

## **INTRODUCTION**

History of Architectural Review in Bexley  
Organization of the Guidelines  
Using the Guidelines  
Property Owner, Staff, and Commission Responsibilities  
Purpose and Intent of the Design Standards and Guidelines

## **DEFINITIONS**

### **PROCESS AND PROCEDURES**

Bexley Boards and Commissions and their respective responsibilities  
Obtaining a Certificate of Appropriateness  
Administrative Approvals  
When a Certificate of Appropriateness is Not Required  
Denial of a Certificate of Appropriateness  
Code Enforcement  
Flow Chart  
Bexley's Zoning District Map

### **THE HISTORY AND ARCHITECTURE OF BEXLEY**

History of the Building of Bexley  
Building Typology- Commercial, Civic, Residential, Religious  
Architectural Style

### **THE LANGUAGE OF ARCHITECTURE**

Expressing the special Character and Diversity of Bexley Architecture  
Understanding Style vs Language  
Proportion, Massing, Alignments, Hierarchy, Propriety, Materials  
Using the Language- Examples of additions/ improvements/new builds/  
context (tree coverage, streetscape, coverage)  
Large Homes/Large lots  
Central Bexley house  
South Bexley house  
North Bexley house  
Commercial/civic/religious

### **NEW SITE CONSIDERATIONS**

Fencing Considerations  
Lighting Considerations  
Parking Considerations  
Landscaping

# TABLE OF CONTENTS, (CONT.)

## **SUSTAINABILITY**

Material choices, etc....

Restorative Environmental Design Standards

Respect/interaction with the environment (tree commission , arboretum...)

Life cycle analysis (ASTM standard) - tim - analysis of historical windows

Restorative Environmental Design Standards (see quotes at end of this DOC)

## **DESIGN GUIDELINES FOR NEW CONSTRUCTION**

New Buildings and Additions

Other Garage Considerations

Other Addition Considerations

## **DESIGN GUIDELINES FOR PRESERVATION AND REHABILITATION**

General Rehabilitation Advice

The Secretary of the Interior's Standards for Rehabilitation and Parks Tech service reports.....

Amendments to the Sec of Interior Standards for Bexley

Massing - Further Examples of "types"/compositions

Using Substitute Materials - use photographs

Details- examples of good - photos

Foundations

Masonry

Wood Siding and Trim

Roofs/Roof Replacement Guidelines

Gutters and Downspouts

Windows

Doors and Entrances

Porches and Stoops

Storefronts

Signage

Awnings

Commercial Cornices, Parapets and Upper Facades

Adaptive Use

Access for the Disabled

Color

Garages and Outbuildings

Landscape Features

Solar Panels

## **LINKS**

Bexley Zoning Maps

Applications

Certificate of Appropriateness Application

# INTRODUCTION

## **THE HISTORY OF ARCHITECTURAL REVIEW IN BEXLEY:**

In 1999, the City of Bexley established Architectural Review. The Board of Zoning Appeals was the body determined to serve as the Architectural Review Board and served as the final determination of the issuance of a Certificate of Appropriateness. In the years that followed the process was codified and the configurations of the Boards and Commissions have changed. Currently the responsibility of design review and the issuance of a Certificate of Appropriateness is with the Architectural Review Board and the Board of Zoning and Planning.

## **ORGANIZATION OF THE GUIDELINES:**

These guidelines are intended to help property owners and applicants succeed in getting what they need programmatically while improving the built environment in the City of Bexley. This document includes reference examples of the architecture, language and styles found in the city of Bexley as well as guidance for the process and design for new projects.

## **USING THE GUIDELINES:**

The design guidelines are an evolving, living document and should be a constant reference tool for property owners, designers, staff, commissions and boards. It is meant to be easily accessible and user friendly to our residents. Please contact the building department at 614-559-4240 for assistance if needed.

## **PROPERTY OWNER, STAFF AND COMMISSION RESPONSIBILITIES**

It is the responsibility of the property owner to file the appropriate application for approval. Staff is responsible for the review of the application and insuring that it is in the appropriate process. The Boards and Commissions are responsible for evaluating each application fairly and on its own merits.

# PURPOSE AND INTENT OF THE DESIGN STANDARDS AND GUIDELINES

The purpose of Architectural Review is to maintain the quality and existing character of the City of Bexley. The Architectural Review Board (ARB) is charged with the responsibility of assuring that new buildings and exterior changes to existing buildings are compatible with and do not adversely affect the surrounding neighborhood.

The Board does not review normal repair and maintenance. Board members are all residents of the City of Bexley, and include citizens with real estate, legal, building and design experience. No new building can be constructed and no existing structure can be enlarged or have its architectural style and details changed, unless the City issues the property owner a Certificate of Appropriateness. In deciding whether to issue the certificate, the ARB considers many elements such as architectural design, exterior materials and detail, height and building mass, placement of buildings on the site, grade levels, etc... The goal is not uniformity of design since Bexley has many different architectural styles. Instead the goal is to foster compatible design which respects a home's existing style and its surroundings.

The Design Guidelines will serve as a model for property owners to improve their individual properties. These guidelines will assist and inspire property owners in their property improvement efforts and establish a base level of what is expected by the city. In addition, these guidelines will aid the fair and consistent review of applications by the Architecture Review Board.

Successful implementation of design guidelines has been a key in maintaining or revitalizing residential neighborhoods throughout the country. This set of guidelines and standards will enable those that wish to redevelop, renovate, or rebuild portions of their homes and property to meet and exceed the quality of character established by the existing high quality architecture that defines Bexley. These guidelines are intended to approach property improvement in a reasonable and economically responsible way while focusing on improved site design and architecture.

An important factor to consider in the implementation and administration of



# DEFINITIONS

## **ARCHITECTURE AND IT'S "GIVENS":**

Givens are (generally) not choices that the architect will get to make. These givens exist but will be uniquely interpreted by the architect. They can be challenging and they can be challenged. But they will mostly stay the same.

## **PROGRAM:**

The program is the desires and needs of the owner and user(s). This is often referred to as the scope of work and contains functional requirements as well as "in my dreams" desires. These are typically mundane lists of things such as, what type of spaces will be needed, how many bathrooms, what is needed for storage, code requirements, etc...as well as the dream list of the client - the designers will go through these lists of requirements and desires and work with the stakeholders to condense, refine, merge, etc... to create the most efficient use of the space. As one would expect - the budget will often dictate what gets in and what gets tossed from the list. Clients often come in with complicated spreadsheets and lists - good designers will simplify these into forms such as bubble diagrams are often used to help in understanding adjacencies and relationships of spaces.

## **CONTEXT:**

Where is the project located? What is the context? What are the rules and codes? Context is of unique importance to architecture. Architecture is almost always specific to its context. A project should respond to its neighbors, the street, the codes and guidelines of the city. Much like a building needs the right scale, it also needs to be built in context. This means that the building suits its surroundings in style, materials, and proportion. A glass skyscraper rising on a block of low-rise, brick houses would be referred to as "out of context."

## **ENVIRONMENT:**

The circumstances, objects, or conditions by which one is surrounded. Understanding the environment is an important factor in the way the architecture is created. It is essential to take into account the climate, the seasonal changes, temperature extremes, etc... examples in which building design are directly related to environmental conditions would include solar panels, eco cities, buildings using the earth, green/sustainable structures, etc...

# DEFINITIONS, CONT.

## **PHYSICAL CHARACTERISTICS OF ARCHITECTURE:**

### **STYLE:**

Style combines elements that make structures unique and different from other styles and make a building historically identifiable. A specific style includes a unique combination of the architectural elements and/or method of construction. These combinations make it possible to differentiate architectural styles.

### **MASS:**

Massing is the size of the building and the 3 dimensional form of a building. Scale can make very massive buildings visually appealing - generally buildings are constructed to human scale. Even very large buildings with large masses can be scaled to be comfortable to the human eye. These massive structures have details that are human scale such as windows, doors, trim, etc...

### **SCALE:**

Scale plays a very important role in architecture and refers to the size of something compared to a reference standard or to the size of something else (like a human being). Human scale is a term you will hear often in ARB meetings - especially in reference to how a building is humanly relatable. The scale of a building can make a building comfortable or uncomfortable for the user.

### **VOLUME:**

Volume refers to the amount of enclosed, contained space.

### **STRUCTURE:**

Structure will often dictate form. Older buildings are much more adherent to the structure whereas modern technology allows more flexibility of form. However, architecture will never be free of structural constraints.

### **MATERIALS:**

Materials such as concrete, steel, stone, brick, wood, and glass, all influence design and should be incorporated in a historically accurate manner.

### **SYMMETRY:**

The relationship of the family of parts to the whole building. Includes notions of rhythm, strict bilateral symmetry, localized symmetries, natural/anthropomorphic parallels.

# DEFINITIONS, CONT.

## **DRAWING TOOLS AND CONVENTIONS:**

**Scale:** An accurate indication of the relationship between the distances from point to point on a drawing and the corresponding actual distances.

**Floor Plan:** A drawing that depicts the view from above with accurate scaling of all details.

**Elevation:** A drawing that depicts one vertical plane or view of a structure with accurate scaling of all details.

**Section:** A drawing that depicts an elevations sliced vertically through the middle in order to reveal interior arrangements. This type of drawing is extremely helpful to understand the character of interior spaces.

**Axometric:** Using an orthographic projection of a building, on a plane inclined to each of the three principal axes of the object; three-dimensional to scale but without perspective. This type of representation helps the viewer understand how the buildings elevations connect and relate to each other.

**Perspective:** The art of drawing solid objects on a two-dimensional surface so as to give the "right" impression of their height, width, depth, and position in relation to each other when viewed from a particular point. These can be both quick sketches or complex renderings.

***\*All submissions must include plans and elevations of the entire building and a site plan to show the context. All drawings should be scaled.\****

Complex, large buildings may require large numbers of such plans, elevations, and sections.

Complex curved buildings and irregular shaped buildings require even more elaborate methods of representation such as models or axonometric representations.

"We look at a building. Instantly we are charmed by it--we say "what a lovely building". But for an artist this instinctive judgment is not enough. He asks himself why it is beautiful and tries to analyse all those features of the building which charm him, so that he may be able to apply himself to synthesis when he comes to create in his turn."

- Voillet le Duc

# DEFINITIONS, CONT.

How language is used to describe architectural design is often unfamiliar to the applicants that come before the Architectural Review Board for approval and the issuance of a Certificate of Appropriateness. Often these terms or descriptions can seem very subjective but they are widely accepted in the Design professions.

## **THE FOLLOWING TERMS ARE OFTEN USED BY OUR ARCHITECTURAL REVIEW BOARD:**

Compatibility: Capable of existing in harmony together.

Consistency: The harmony of parts or features to one another or a whole.

Historical: Characteristic of the past whether reproduced or rehabilitated.

Beautiful: Aesthetically pleasing by proper use of massing, scale, materials, etc...

Imitation: Resembling something else that is usually genuine and of better quality.

Quality: Elevated materials, design, structure, etc...

High quality: Superior materials, design, structure, etc...

Unique: Special through the proper use of massing, scale, materials, etc...

Uniformity: Consistency of style, materials, proportion, scale, etc...

## **THE FOLLOWING ARE COMMON TERMS OF CHARACTER DEFINING ASPECTS - THESE ARE OFTEN SPECIFIC THINGS THAT MAKE A BUILDING FASCINATING:**

Diverse architectural styles: Containing a variety of architectural styles whether within a single structure or the neighborhood yet the compatibility, massing and scale remain consistent.

Architecturally significant: A structure that is high quality and a significant contributing part of the neighborhood

Aesthetic character: A structure that exhibits the characteristics defined in the above section and is therefore an contributing component of the neighborhood.

Matching: Using the same materials, construction techniques, detailing as the existing structure or historic precedent.

Discordant: The materials, construction techniques and detailing are not compatible with the existing structure or historic precedent.

# PROCESS AND PROCEDURES

## **BOARDS AND COMMISSIONS:**

**The Architectural Review Board (ARB):** The ARB hears applications for exterior architectural changes to residential and commercial properties. The ARB meets the 2nd Thursday of the Month at 6:00pm in City Hall. The purpose of the ARB is promote, preserve and enhance the existing character of various residential neighborhoods in the City by encouraging the retention of buildings which have historic, architectural or cultural value or which are otherwise worthy of preservation, maintaining lot size and building scale appropriate to each neighborhood, and minimizing or avoiding the adverse potential impacts of vacant lots within fully developed neighborhoods; to promote and improve the quality of neighborhoods and commercial corridors by permitting the demolition and replacement of existing residential buildings when they are not worthy of preservation or cannot be economically maintained or restored or when there are other compelling reasons to do so; to protect and preserve property values and the City's tax base; and to promote the general welfare by regulating the demolition or removal of existing structures, the exterior characteristics of new structures and the modification of existing structures throughout the City.

**The Board of Zoning and Planning (BZAP):** The BZAP hears and renders decisions concerning variance requests, and provides recommendations to council regarding City planning efforts and rezoning. This board was established to control, encourage and regulate the character, design, placement and relationship of buildings, structures and spaces within the City of Bexley. An application goes before the Board of Zoning and Planning for variances, conditional use permits, and development/planning approvals and recommendations to City Council. The Board of Zoning and Planning meets the fourth Thursday of the month at 6:00pm in City Hall.

**The Bexley Community Improvement Corporation (CIC):** The CIC is a development agent of the City of Bexley.

**The Tree and Public Gardens Commission (TPGC):** The TPGC consists of five members appointed by the Mayor. The duties of the Commission are to study the problems and determine the needs of the City of Bexley relative to a municipal tree care and tree planting program, develop a written plan for such, and make recommendations to Bexley City Council as to legislation concerning the tree program and activities for the City of Bexley.

**The Historic Preservation Working Group:** This workgroup was created to implement new practices towards the preservation of historic structures within Bexley, and to recognize the benefits of preserving our existing quality in order to maintain the historically unique character seen throughout our community.

### **Obtaining a Certificate of Appropriateness:**

Any changes to the exterior of a building including everything from one new window to an entire new structure needs to obtain a Certificate of Appropriateness. This is done through the City of Bexley's website, Building and Zoning Department, Viewpoint online permitting system. (<https://bexleyoh.viewpointcloud.com/>)

Upon receipt of the application staff will determine the next step. Exterior changes with no variance request(s) will either be done by staff or the Architectural Review Board. If a variance is needed the applicant will need to go to both ARB and the Board of Zoning and Planning. (Refer to Bexley City Codified Ordinance Chapter 1223, Architectural Review

### **When a Certificate of Appropriateness is Not Required:**

There are some things that do not require review and approval though staff is there for the residents of Bexley to help guide and assist with these projects as well. These things include painting, soft landscaping of private property, and like for like replacements that do not require building permits. Please check with the building department to be certain that your project does not need Architectural Review.

### **Code Enforcement:**

Bexley's Code Enforcement officer will sometimes site a property owner for projects in process that warrant but have not received Architectural Review. This is not meant to be punitive but is in the best interest of the owners and neighboring properties. Staff will be happy to assist in getting the right process started.

### **Denial of a Certificate of Appropriateness:**

If an application for a Certificate of Appropriateness is denied by the applicant can appeal the decision. The process for appeals is in Bexley's Codified Ordinances.

# ADMINISTRATIVE APPROVALS:

Routine repairs and maintenance do not require the approval of the ARB when the work is completed using matching materials and design. Existing architectural details, including trim, shutters, columns, porches, windows and other elements shall be retained. If certain elements have deteriorated beyond the point where they cannot be retained, they shall be replaced in kind. However, any modification or deletion of existing exterior architectural details requires a certificate of appropriateness. Examples of staff approvable items:

## **WINDOWS:**

When windows are replaced they should remain true to the architectural style and proportions of the original windows. There is flexibility in the use of materials providing the profiles and predominant details can be maintained.

## **ROOFS:**

Areas of deteriorated shingles can be replaced without replacing the entire roof if the new shingles match the material, color, texture, and profile of the existing roof. Asphalt shingles shall not be used to patch a slate, wood shake or shingle, or tile roof. Distinctive roofing materials, including slate, copper, clay tile, and wood shakes, shall be repaired and maintained whenever possible. If a roof is deteriorated beyond repair, asphalt or fiberglass reinforced asphalt shingles are acceptable alternatives in most cases. Slate, synthetic slate, cedar shakes, and other roofing materials are encouraged for some houses, based on architectural style. (See roof replacement section for additional requirements for a change in roofing materials.)

## **PORCHES, RAILING, STEPS, DECKS:**

When porches, railings, steps, decks, or other exterior elements are replaced, pressure-treated wood is acceptable for structural members but a higher grade of lumber, such as cedar, redwood or cypress, is recommended, but not required, for all finish elements, including posts, railings, fascia and trim, stair risers and treads, and other visible features.

## **SHUTTERS:**

If shutters are replaced, the new shutters shall be equal to the height of the window and approximately half its width. The shutters shall be installed so that the bottoms of the shutters align with the tops of the windowsills. If the window is too wide to allow shutters to meet this standard, then it likely was not intended to have shutters at all.

## **WINDOW AND DOOR REPLACEMENTS:**

Replacement windows and doors which replicate the size, style, color and appearance of existing windows and doors are permitted and may be reviewed and approved by staff.

## **RE-POINTING/TUCK POINTING:**

Mortar used to re-point existing brick or stone shall match the color of the mortar on the existing building; the width and profile of the mortar joints shall also match the existing condition and historic mortars shall be used per referenced NPS technical report.

# PROJECT FLOW CHARTS

## NO VARIANCE NEEDED

**APPLICATION REVIEW**  
NO VARIANCE

**DISTRICTS:** R-1, R-2, R-3, R-6, R-12, CS, GC, OS, MUC

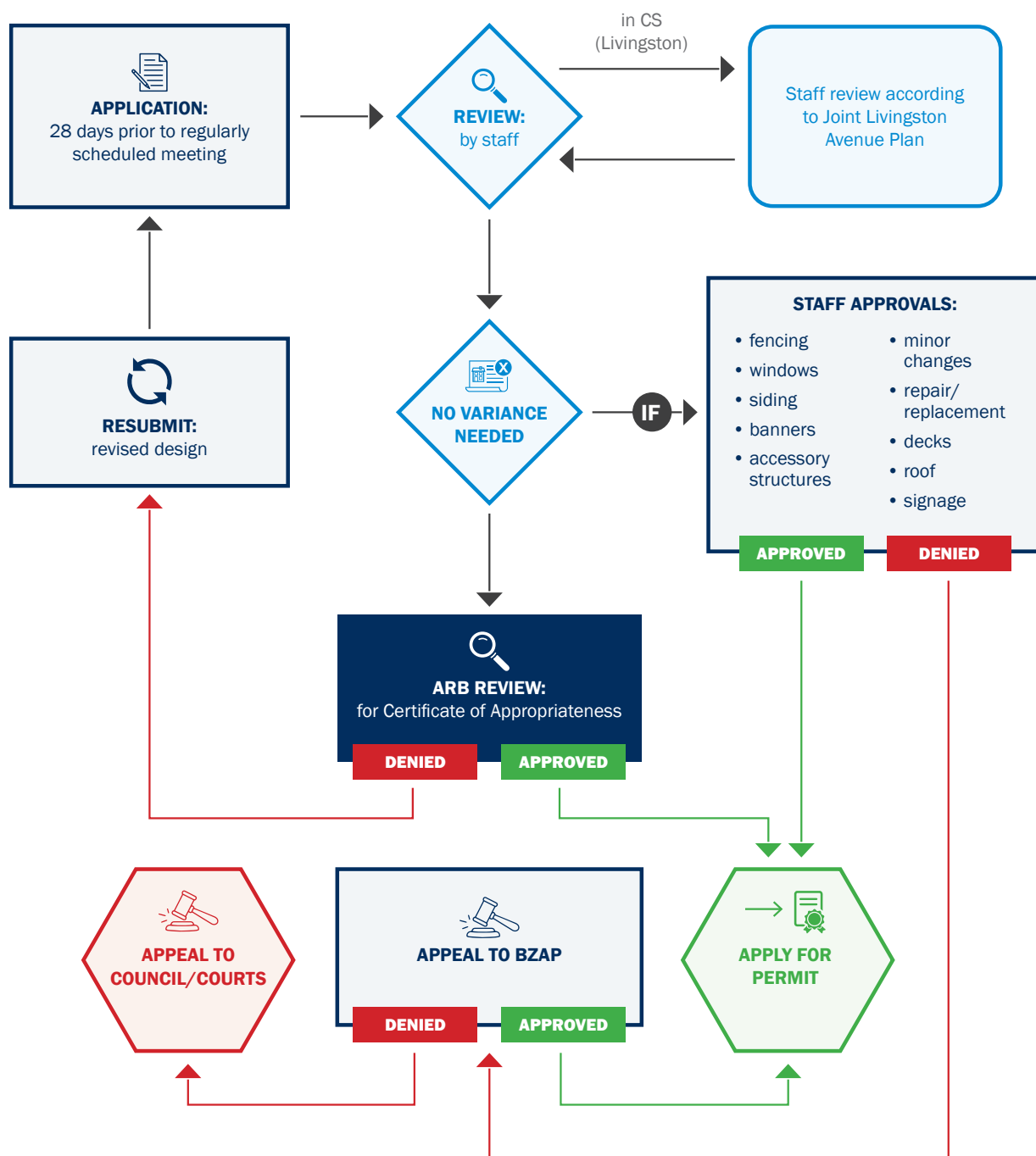



# PROJECT FLOW CHARTS, CONT.

## VARIANCE NEEDED

**APPLICATION REVIEW**  
**VARIANCE NEEDED**

**DISTRICTS:** R-1, R-2, R-3, R-6, R-12, CS, GC, OS, MUC

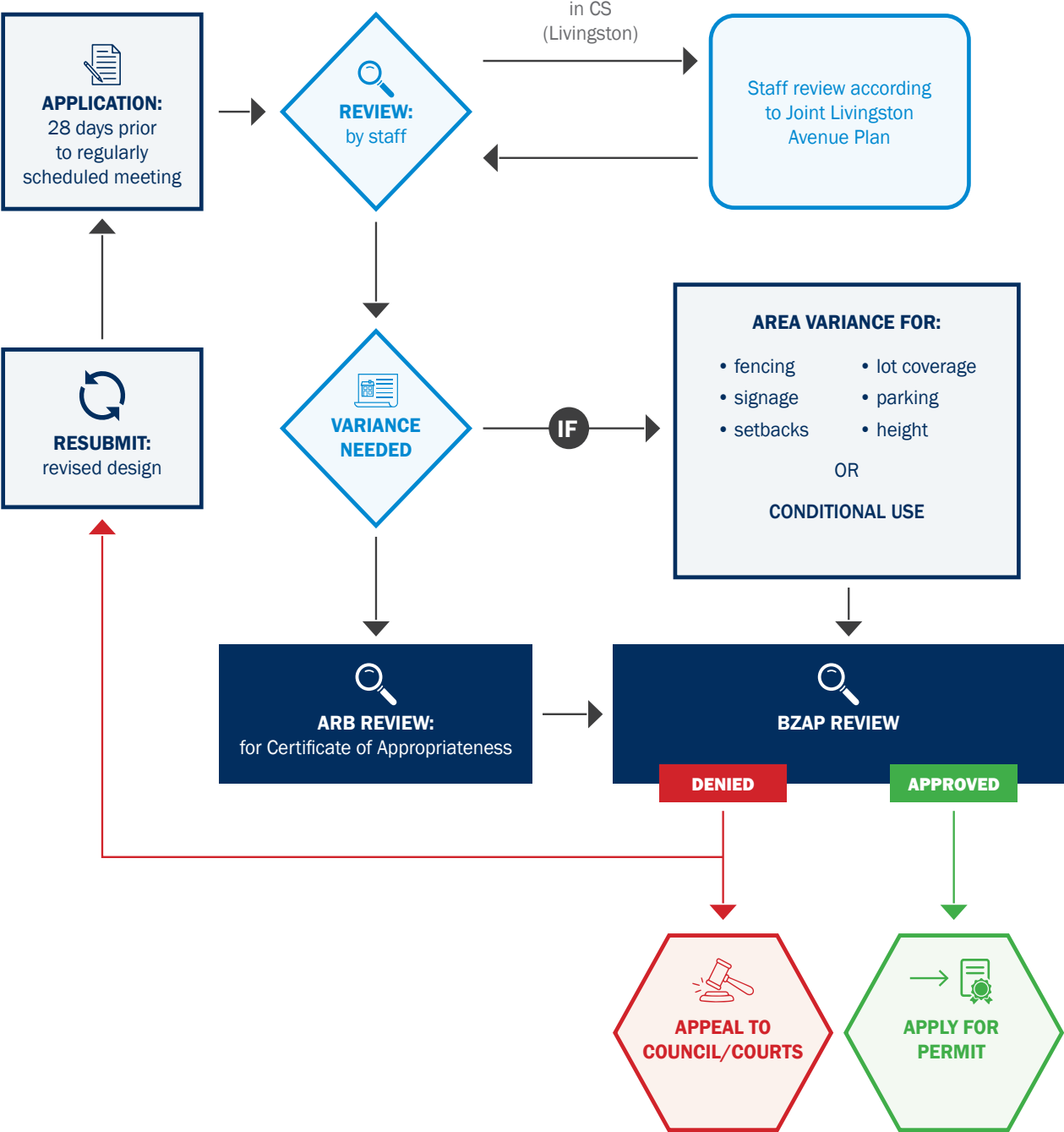
# PROJECT FLOW CHARTS, CONT.

## PLANNING PROJECTS

### APPLICATION REVIEW NO VARIANCE



**DISTRICTS:** R-1, R-2, R-3, R-6, R-12, CS, GC, OS, MUC

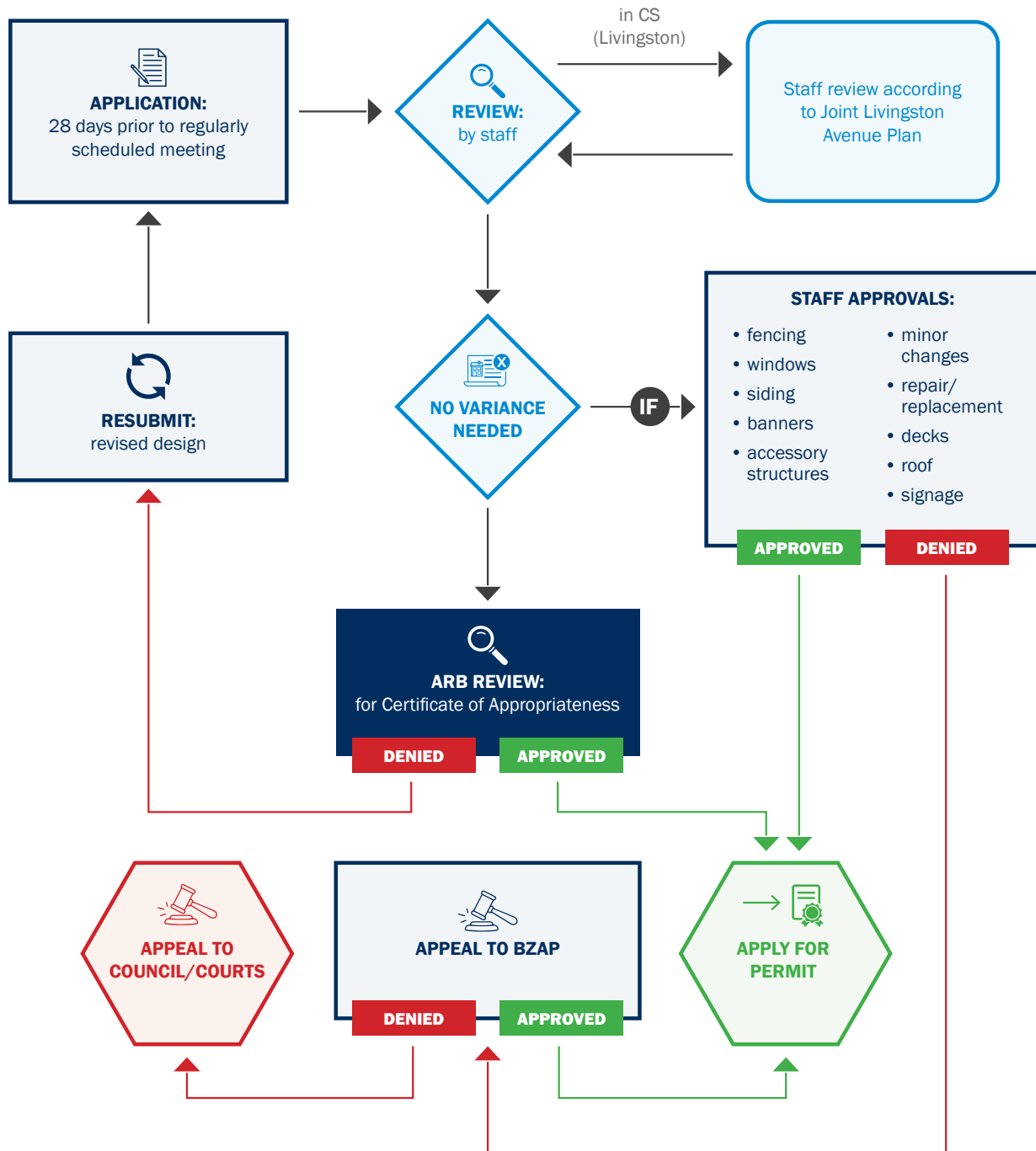

# PROJECT FLOW CHARTS, CONT.

## LOT SPLITS

**LOT SPLIT**



**DISTRICTS:**

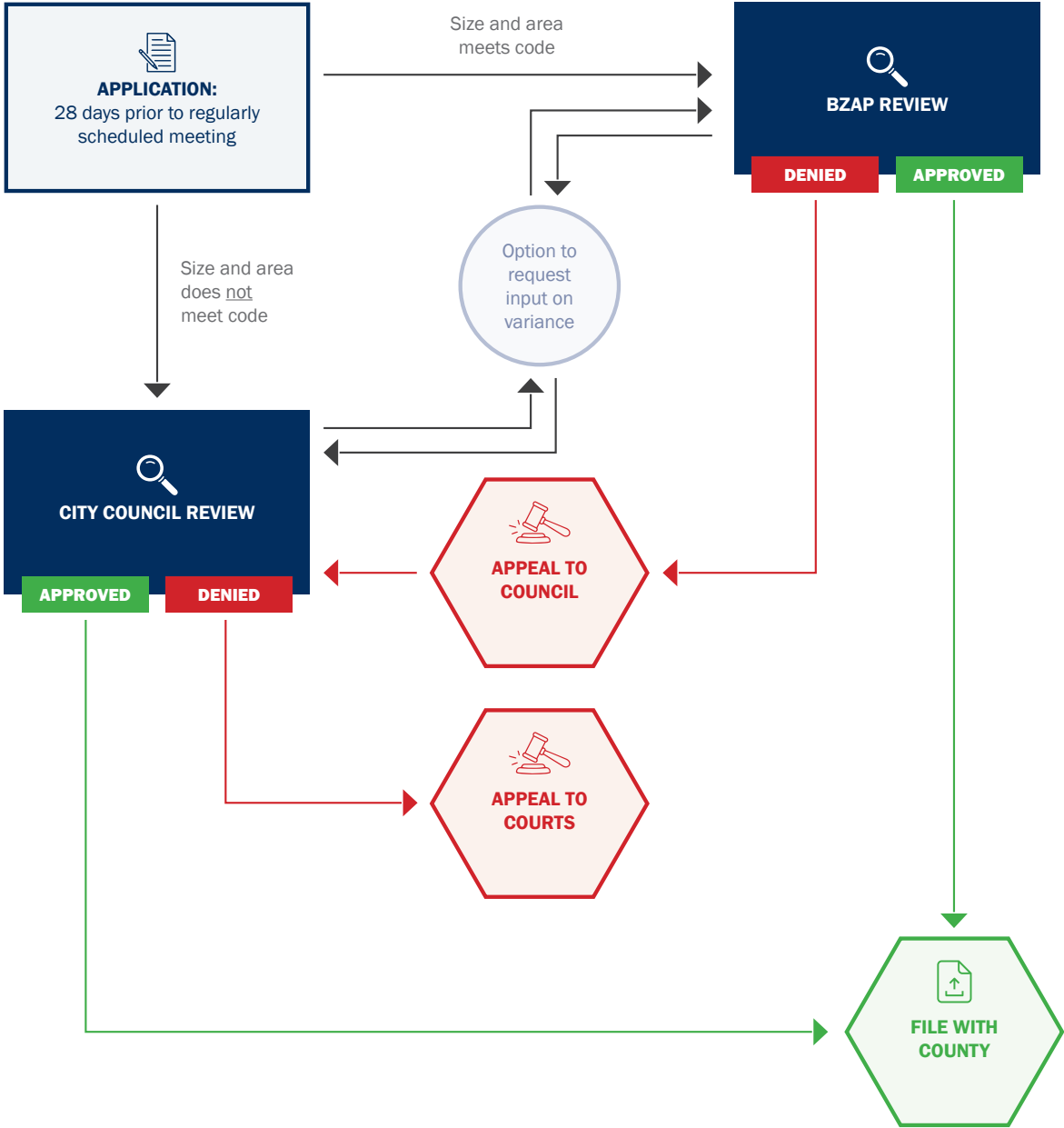

# THE HISTORY AND ARCHITECTURE OF THE CITY OF BEXLEY

## Introduction

by Lawrence Helman, Planner

Member, Architecture Review Board and Tree and Public Garden Commission

Incorporated in 1908, the City of Bexley is a historic first-ring suburb of Columbus that is best known for its community of neighborly, tree-lined streets, its excellent schools and places of learning, and first-class restaurants, art galleries, and places of business.

Bexley is an architectural treasure. One's first drive up the Broad Street hill reveals an incredible display of early 1900's architectural styles rich in detail, including Tudor, French Normandy, classical revival and more. This architectural heritage extends well beyond just the large estate houses and includes more modest sized houses that continue the same richness, style, and attention to detail. On the many north-south streets off of Broad, Main, and Livingston can be found Dutch colonial, Tudor, Spanish and French designs, classical revival, cottage style, and, in later developments, cape cod and modernist styles. These styles coexist on orderly tree lined streets while other streets exemplify the almost continuous use of front porches onto the street, creating a sense of friendly neighborhoods, a shared community.

Much of Bexley's housing stock is at or beyond 100 years in age, and many houses have undergone extensive renovations, additions, and in rare cases demolition and thoughtful, well designed replacement. It is the purpose of the Bexley Architectural Review Guidelines to both encourage and promote the continuing renovation and redevelopment of Bexley's housing stock over time while also ensuring its preservation so that new construction fully honors and enhances Bexley's unique architectural character well into the next century.

(Insert narrative here of Bexley's Zoning District Map and the Bexley Neighborhoods Map re: different ways of looking at the city)

# BEXLEY NEIGHBORHOODS

- A** BULLITT PARK / PARKVIEW / PARK HILL / PARKVIEW ROWND
- B** HAMILTON'S GARDENS / SHERIDAN PARK
- C** BEXLEY PLAZA / EASTLAWN / LIVINGSTON HEIGHTS
- D** STANBERY
- E** ARDMORE NORTH
- F** ARDMORE SOUTH
- G** BEXLEY PARK / RUDOLPHS FAIRWOOD / BEXLEY HIGHLANDS
- H** BELLWOOD

## SPECIAL CHARACTER ZONES

- 1 SESSIONS VILLAGE
- 2 LYONSGATE / BISHOP SQUARE
- 3 BULLITT PARK PLACE
- 4 BELLWOOD CAPE CODS
- 5 MERKLE ROAD STONEWORKS
- 6 ARDMORE 1950S
- 7 PLEASANT RIDGE / FRANCIS AVENUE
- 8 EUCLAIRE AVENUE PORCHES
- 9 HAVENWOOD / CIRCLE PARK
- 10 LIVINGSTON HEIGHTS TUDORS

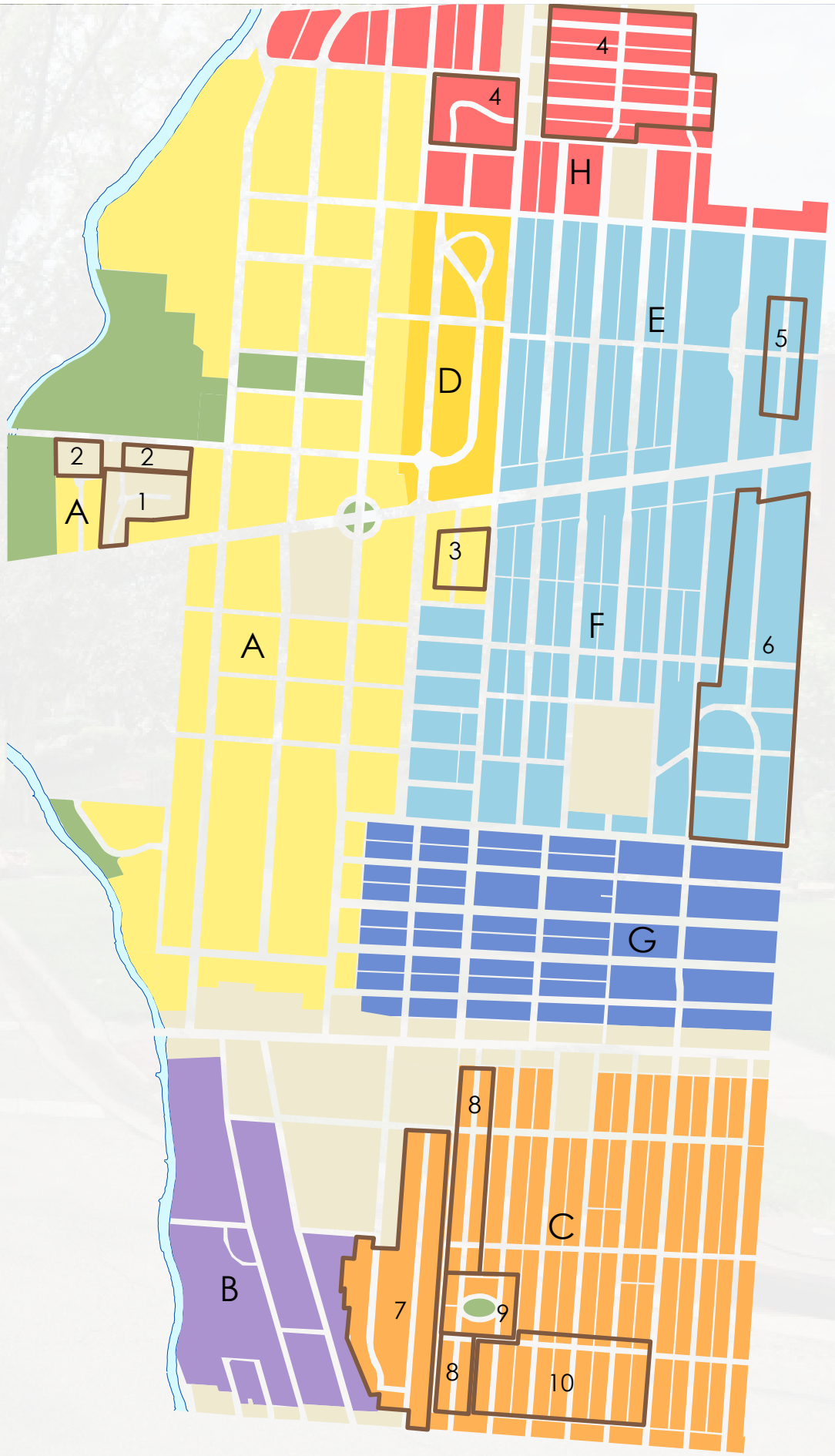

# BULLITT PARK / PARKVIEW / PARK HILL / PARKVIEW ROWND

## NEIGHBORHOOD HISTORY

At the turn of the century in the early 1900s, Columbus, Ohio, expanded in two dominant directions: north along the High St corridor and east along the E Broad St corridor. Beyond Nelson Rd and up the hill from Alum Creek were large tracts of land prime for residential expansion. In 1908, a regional Columbus Parks Plan led to the creation of major open spaces along Alum Creek including Wolfe Park, setting the stage for the next wave of development along E Broad St. Soon to follow were large residential estates on considerably larger lots than on previous E Broad developments. This was the birth of the Bullitt Park addition.

The Bullitt Park addition provided opportunities for families with means to construct substantial new houses on large lots designed to the latest trends. Houses were generally architect-designed during a rich time in residential architectural themes. Strongly influenced by English manor houses and other European themes, the Bullitt Park houses were constructed using unique materials, craftsmanship, and design features, such as classical forms, leaded windows, and imported slate for roofs. The overall site design for Bullitt Park also represented a commitment to high civic design, which included major

park spaces such as Drexel Circle and Commonwealth Park; brick streets, gutters, and intersection details; and tree lawns and street trees. Also included was the reestablishment of carriage lanes along E Broad St, mirroring their earlier use along Broad St downtown.

An early criticism of the Bullitt Park addition was the use of visually unattractive utility poles that marred the streetscape, unlike its crosstown rival the Country Club of Arlington, with its underground utilities.

Honor the original character of this area, which showcases individually designed houses on larger lots, a high degree of design consistency, a substantial character, use of rich materials, and design details.

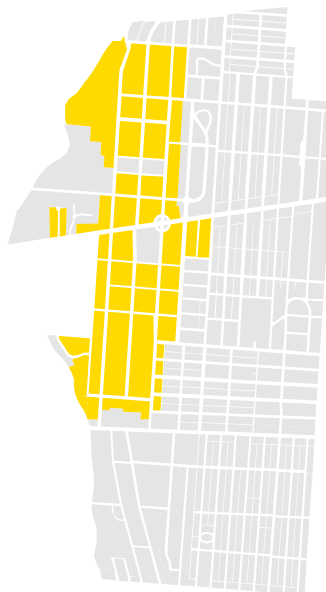



Figure 1. Typical street section. Note the deep setbacks, mature street trees, and abundance of yard trees (front, back, and side). The dashed line on the house to the left shows a condition in which the grade slopes down to a basement-level garage.



Figure 2. Cross-street section. Note the potential for side additions.



Figure 3. Drexel Avenue section. Note the wider street and slightly shallower setbacks.





# BULLITT PARK PLACE

## NEIGHBORHOOD HISTORY

This section illustrates the transition from the larger estate lots on E Broad to smaller, builder-created houses while also extending the 1920s character of the time. For example, the initial development of Bullitt Park Place was a larger model house on the southeast corner at Broad, followed by four smaller, but similarly styled, model houses immediately south on Bullitt Park Place.

Similarly, on the west side of S Cassady

south of Broad Street, a single developer/builder constructed from south to north a row of houses that were architecturally unique but shared common massing and design features. As these houses were developed south to north, the houses incorporated additional interior features such as multiple baths (instead of a single bath) to meet rising market expectations.



Figure 4. Bullitt Park Place section. Note the compact arrangement of the lot and the shallow setbacks.



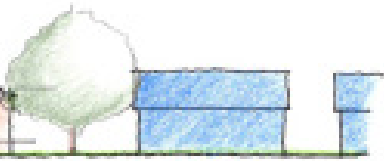
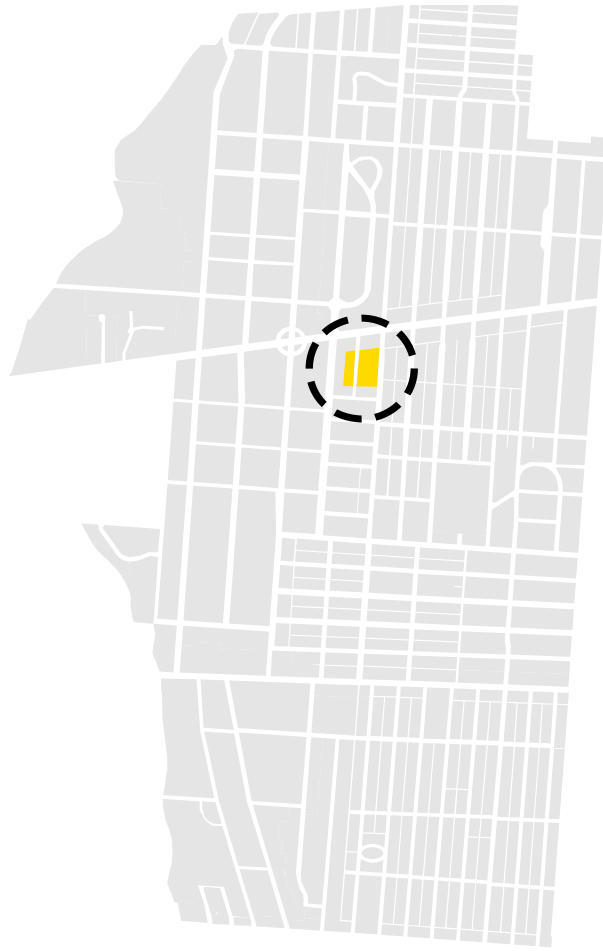

# HAMILTON'S GARDENS / SHERIDAN PARK

## NEIGHBORHOOD HISTORY

Before the Bullitt Park addition, in 1876, Capital University relocated from its downtown, urban setting to a more pastoral site just beyond Alum Creek on donated land along E Main St. Soon to follow was the development of a small residential community of modest houses around and in support of the university, later called the Village of Pleasant Ridge. Development within the Village of Pleasant Ridge did not spawn from an overall plan or grand vision, but instead represented individual lot-by-lot construction of more modest, largely frame houses, many developed and built by members of the Lutheran faith given the nearby concentration of Capital University, the Lutheran Seminary, and Christ Lutheran Church. While lot development adhered to an east-west grid, the skewed angle of College Avenue created an interesting pattern of front yards and larger interior lots that later were subdivided and became Pleasant Ridge Avenue. Honor the original character of the neighborhood's turn-of-the-century village beginnings of largely frame houses with traditional massing, form, architectural trim, and front porches. For Capital University, encourage continued use of brick and masonry to reinforce the existing character of the campus.

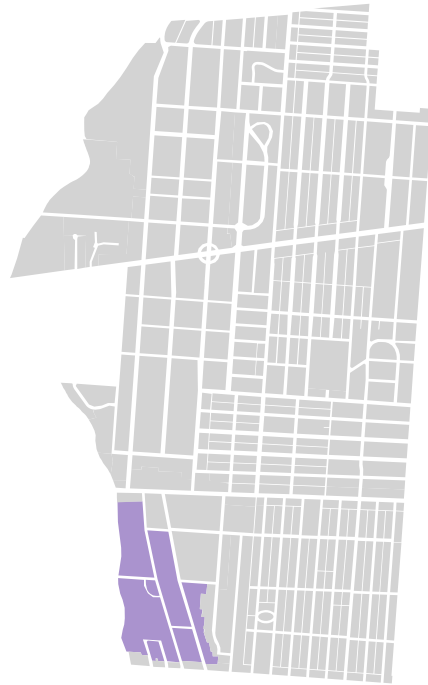

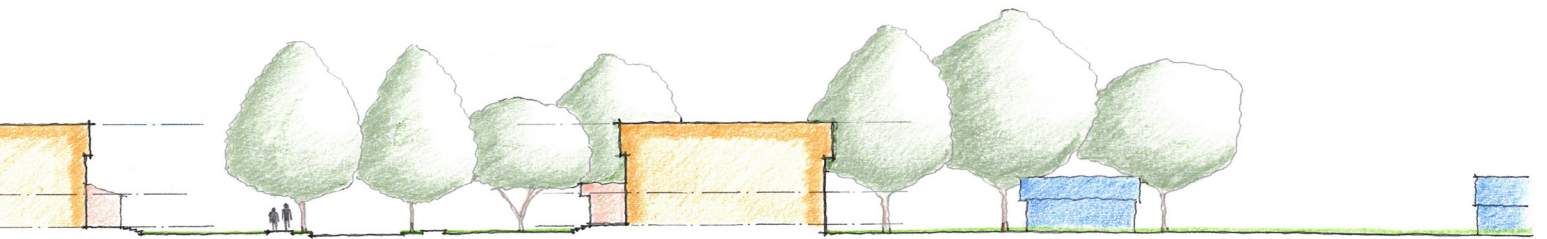

Figure 5. Typical street section.



# HAMILTON'S GARDENS / SHERIDAN PARK, CONT.

The most common house type in this neighborhood has its gable facing the street. It may be a duplex or a single-family house.

The character of these houses stems from the neighborhood's beginnings as the Village of Pleasant Ridge, which consisted of wood-framed houses built by members of the Lutheran community in Bexley. Note the front porches and the

siding, which originally would have been wood lap siding or shingle. Some of these houses have an occupied attic or third floor and have windows where these sample houses have a semicircular vent. Note that although the houses are slightly different styles, their first floor levels, floor-to-floor heights, eave heights, and ridge heights align.

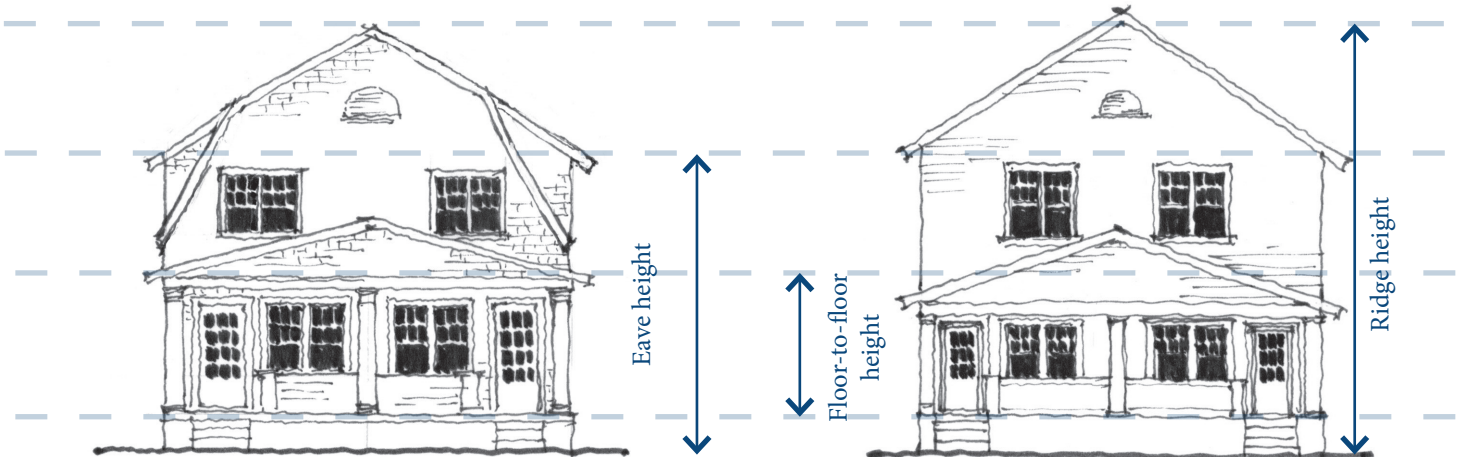

The drawing to the right shows a sample lot. Characteristics of note include the parallelogram-shaped lot with the building oriented along the sides of the lot, the street-facing gable front of the house, a front porch, and a detached garage with access from a front driveway.



Figure 6. Sample lot.

**A.** The most common house type has its gable facing the street.

**B.** Porches are very common in this neighborhood.

**C.** Garages in this neighborhood tend to be detached. Due to the absence of alleys, access is from a front driveway. Not all houses in this neighborhood have garages.

**D.** Lot sizes are highly variable. Lot widths range from 35 to 100 feet; the lower end of this range may not allow for side additions. Lot depth varies from 100 to 200 feet, with the most common depth being approximately 180 feet. Setbacks vary widely, averaging 50 feet (measured perpendicular to the facade of the house).

**E.** Other common house types are 2-bay and 3-bay single-family houses.

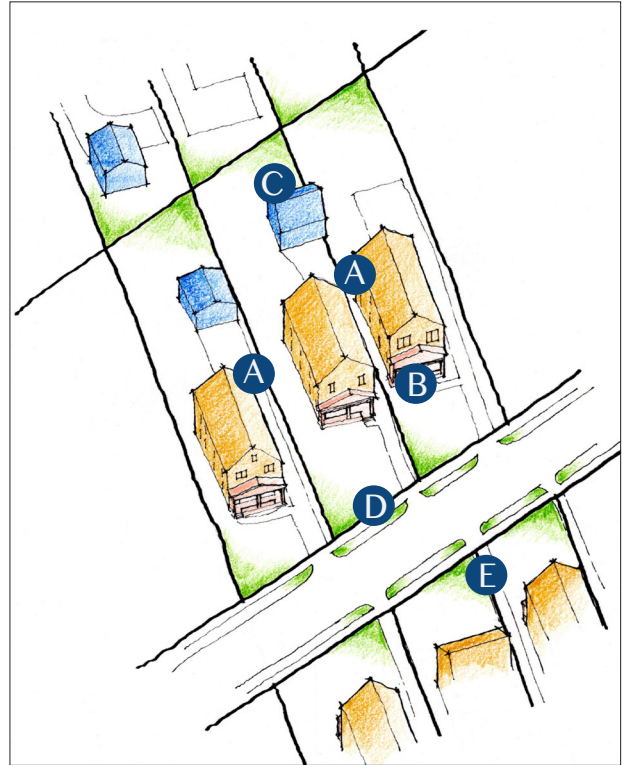
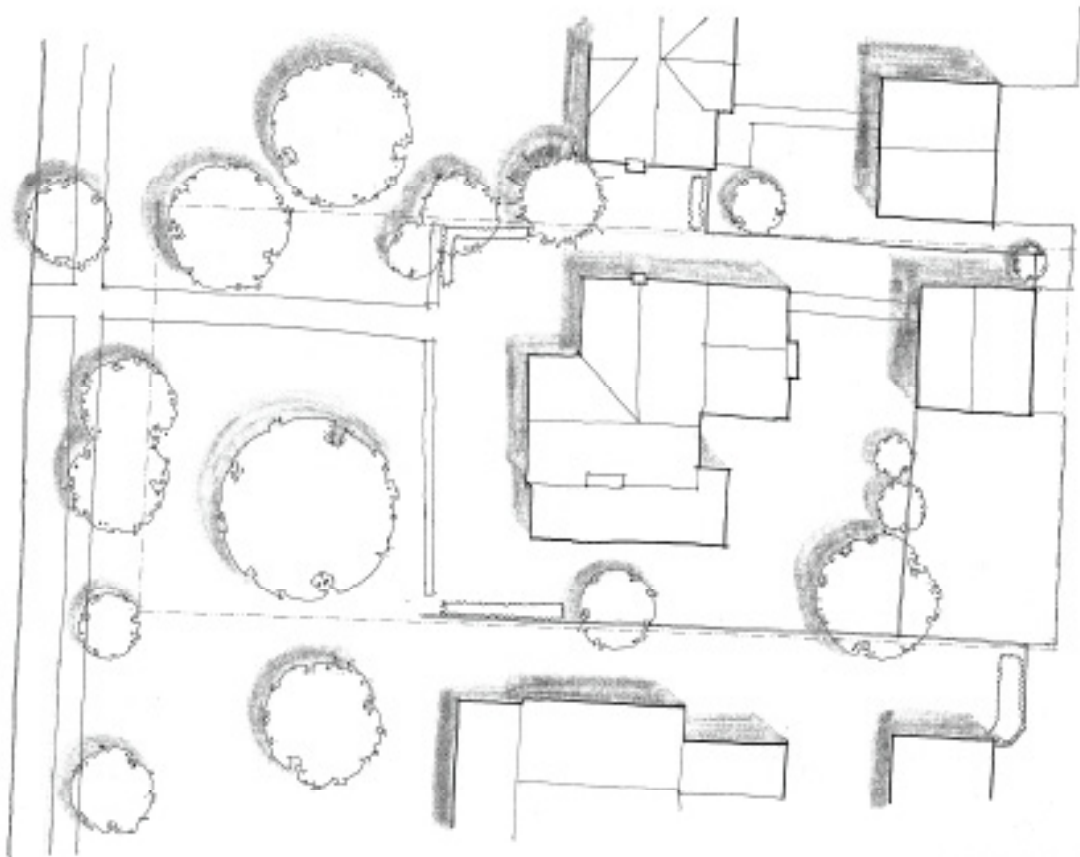

Figure 7. Street aerial.



# BEXLEY PLAZA / EASTLAWN / LIVINGSTON HEIGHTS

## NEIGHBORHOOD HISTORY

For the area east of Pleasant Ridge and south of E Main, many smaller subdivisions were developed off of E Livingston Avenue, again utilizing a system of alleys. These also served as access to individual garages in lieu of a driveway, which enabled using a smaller, 40-ft lot width, as opposed to 50 ft. This area comprises a variety of distinctive neighborhoods including Pleasant Ridge / Francis Avenue and Havenwood Park.

The blocks generally run north-south and are uniform in size, with no continuous internal east-west street that connects to College Avenue. Pleasant Ridge and Francis are the longest blocks in all of Bexley. Lots are smaller and narrower than those in Ardmore North and South, creating a more continuous building facade and a tighter, more compact streetscape. This area also has many more front porches that animate the street than Ardmore North and South.

Similarly to Ardmore North and South, the development and character of this area were heavily impacted by the Great Depression. Beginning in the 1920s, development of this area moved in a west-to-east direction, fed from both Main St southward and Livingston Avenue northward. However, within ten years the Depression brought new housing to a near standstill, leaving scattered undeveloped infill lots to the west and a much larger number of undeveloped lots to the

east. To the west, frame and masonry houses along streets such as Euclaire, S Cassingham, and Montrose reflect more traditional styles such as Tudor, Dutch colonial, or cottage designs. In general, the larger houses tend to be in the west of this area. Conversely, the most easterly streets such as Chelsea and Grandon reflect much later house styles, such as smaller, two-story, center-hall (similar to those found in N Roosevelt) and 1½-story Cape Cod houses, which also can be found on infill lots to the west. In addition, the frequency of front porches decreases from west to east. Another distinction between west and east development in Bexley Plaza / Eastlawn / Livingston Heights is the use of stone as an accent material on newer houses, as opposed to the more numerous traditional frame houses as seen to the west.





Figure 8. Typical street section.



Figure 9. Typical cross-street section. Note that the house on the left has an entry on the cross-street and the house on the right has a side addition (potentially a side porch) facing





# BEXLEY PLAZA / EASTLAWN / LIVINGSTON HEIGHTS, CONT.

Due to the relatively small lot sizes, houses in Bexley Plaza / Eastlawn / Livingston Heights tend to be on a small scale: 2- or 3-bay houses, symmetrical or asymmetrical. Porches are very common in this area, from small (covering only the front door) to large (extending across the facade). They tend to be more concentrated on the west side of this area, such as Euclaire Avenue. Other house styles in this neighborhood include ranch houses and Cape Cods (featured in the Pleasant Ridge / Francis Avenue section) as well

as Tudors (featured in the Livingston Heights Tudors section).

Note that while a bungalow may appear smaller than other houses, its first floor level, floor-to-floor height, and its second-floor eave height are still similar to those of a 2-story, 3-bay house. Its lower ridge height is due to the characteristic roof of a bungalow, which has its main eave on the first floor and has a lower roof slope compared to other house styles.

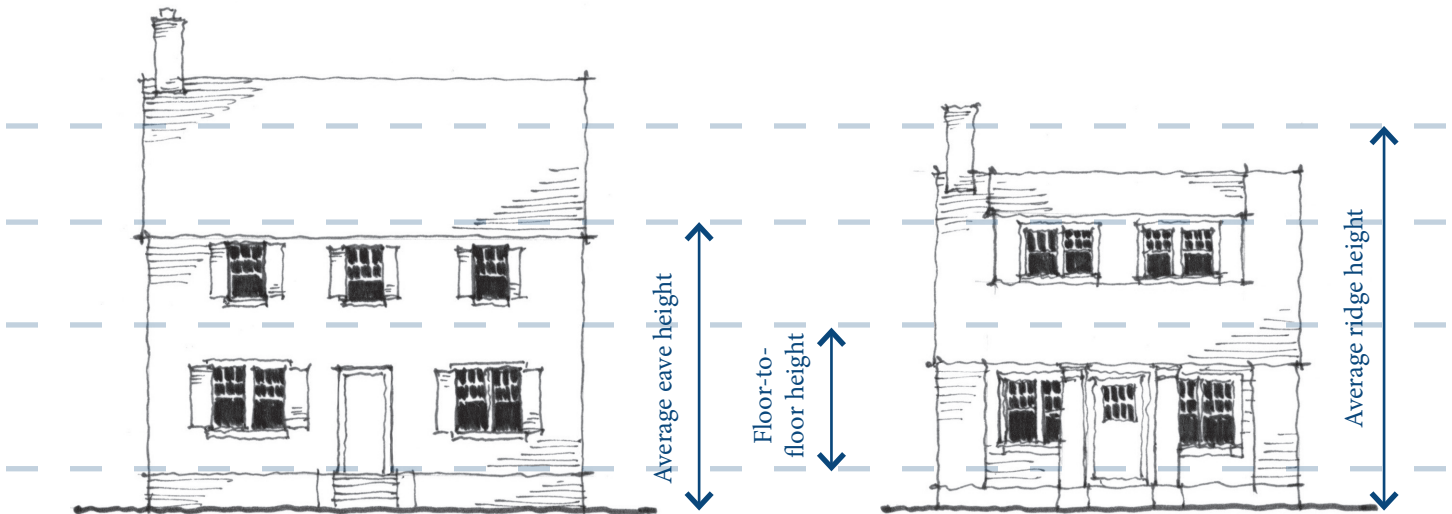

The drawing to the right shows a typical lot. Characteristics of note include the small scale of the house, the presence of a front porch, and a detached garage with entry from the alley behind. Both the street trees and the yard trees tend to be mature trees with large canopies. South Roosevelt Avenue has a wider planter than other streets, and its street trees are larger with wide canopies.



Figure 10. Sample lot.

**A.** The most common house type in this neighborhood is a 2- or 3-bay house, symmetrical or asymmetrical.

**B.** Porches are very common in this neighborhood.

**C.** Garages in this neighborhood tend to be detached, with access from the alleys.

**D.** In Bexley Plaza and Eastlawn, the most common lot size is 40 feet wide by 135 feet deep; in Livingston Heights, it is 50 feet wide by 135 feet deep. Neither lot width is likely to allow for side additions. Setbacks vary from 35 to 55 feet from the edge of the street.

**E.** Other house types found in this neighborhood include bungalows, ranch houses, Cape Cods, and Tudors.

**F.** Corner lots are the same size as other lots. Some houses on corner lots have entries or side porches that face the cross-street. Corner lot garages tend to have entries from the cross-street instead of from the alley. Corner lots may be able to accommodate side additions instead of rear additions.



Figure 11. Street aerial.

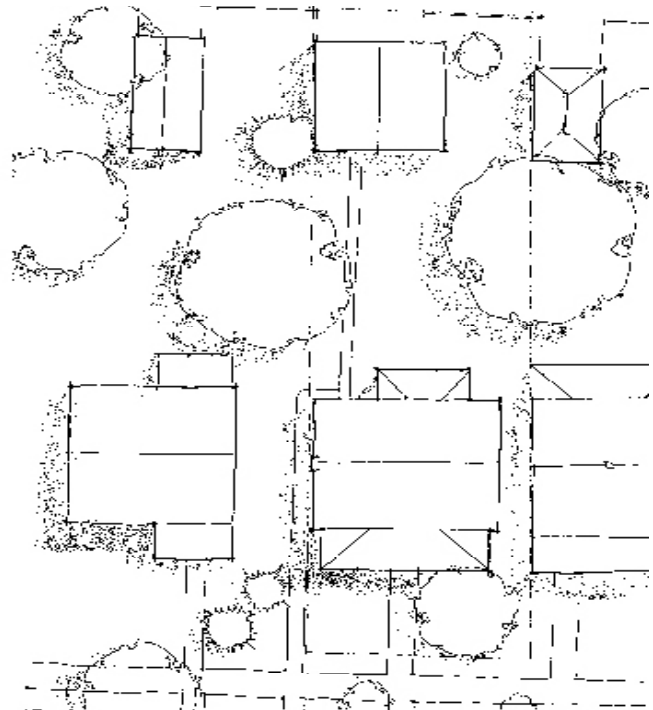

# PLEASANT RIDGE & FRANCIS AVENUE

## NEIGHBORHOOD HISTORY

The development of both Pleasant Ridge and Francis Avenues has in large part been shaped by the physical evolution of the Capital University campus. From its 50 acre original campus acquisition in 1885 , Capital University has since acquired over 100 properties in completing its current campus. For many years, housing along the two northern blocks of Pleasant Ridge was considered “ faculty row” , occupied by the faculty and staff of the university. Over time , the university continued its southerly expansion and acquired these houses. Francis Avenue and the southern extension of Pleasant Ridge occurred in the 1940’s which required a resubdivision of properties to create Francis as a new street. Along Pleasant Ridge three lots south of Astor, housing styles change dramatically from traditional style frame houses to more modern frame and stucco ranches and two story houses to the south. Francis Avenue, Bexley’s longest street between intersecting streets, contains dominantly frame 1 1/2 story houses on larger lots with many that also benefit from being elevated up from the street due to the area’s rolling topography.



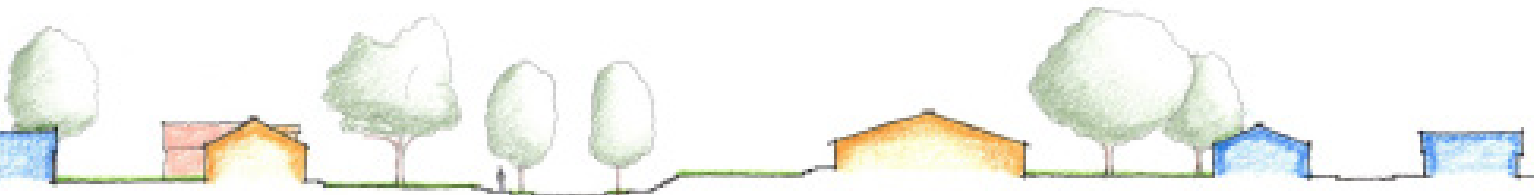

Figure 12. Pleasant Ridge Avenue section. Note the large tree canopies in front yards.

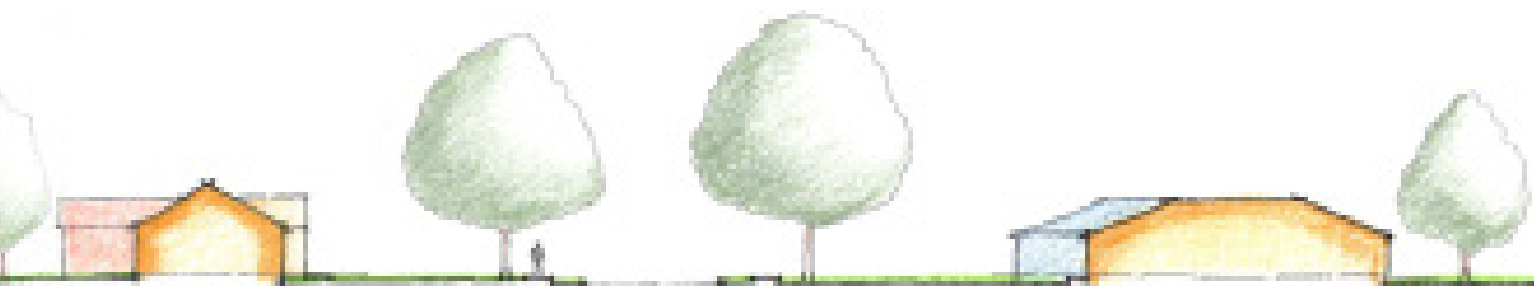

Figure 13. Francis Avenue section.. Note the grade change and the alley on the right (east).



# PLEASANT RIDGE & FRANCIS AVENUE, CONT.

**A.** The characteristic house types of this special character zone are ranch houses and Cape Cods.

**B.** Porches are not as common here as in other neighborhoods.

**C.** Garages tend to be detached, though there are examples of attached garages, especially in ranch houses. Entry is usually from a front driveway. Garages on the east side of Francis Avenue are accessed via an alley.

**D.** Lot widths vary widely, with the most common widths falling between 50 and 60 feet. The most common lot depth is 150 feet; lots on Francis Avenue tend to be deeper. Setbacks vary widely, averaging 60 feet from the street edge.

**E.** Other common house types include the 2- and 3-bay houses seen throughout Bexley Plaza and Livingston Heights.

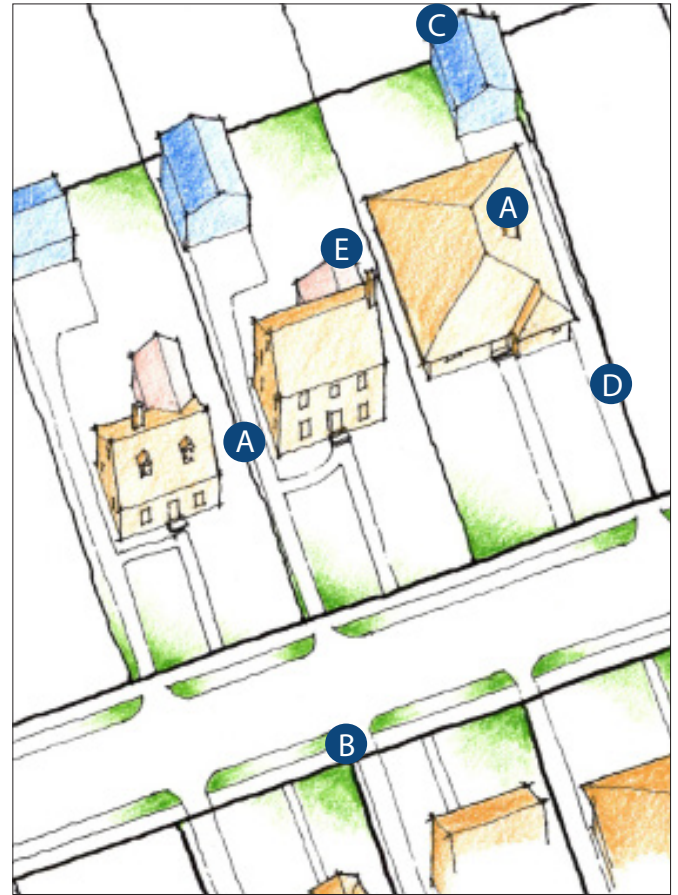

Figure 14. Street aerial.

The drawing to the left shows a typical lot. Characteristics of note include the mature front-yard trees and the lot width, which varies between lots but is on average larger than the 40- and 50-foot lot widths in the rest of Bexley Plaza / Eastlawn / Livingston Heights.

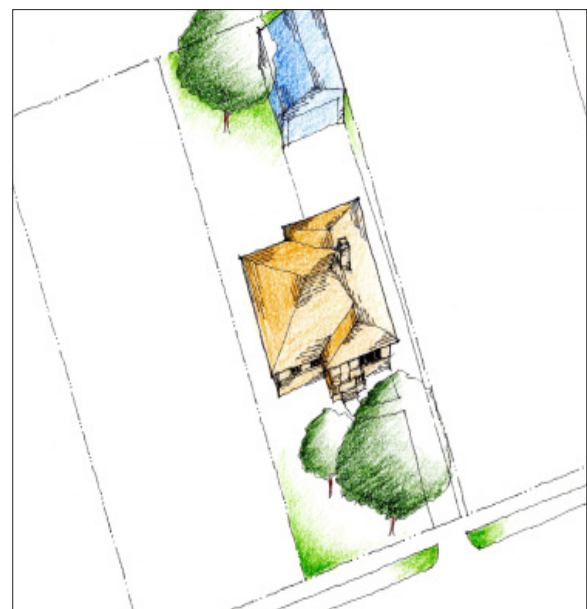
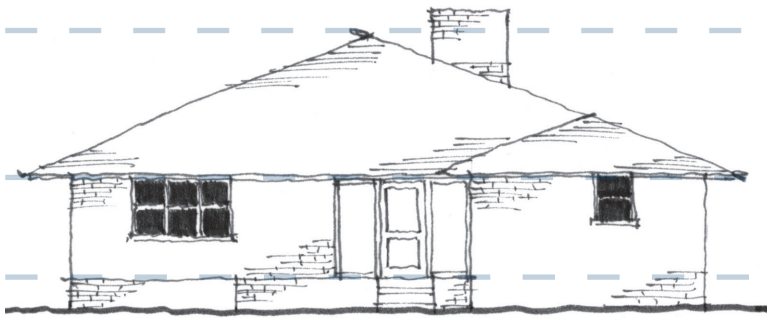

Figure 15. Sample lot.



Eave height



Ridge height

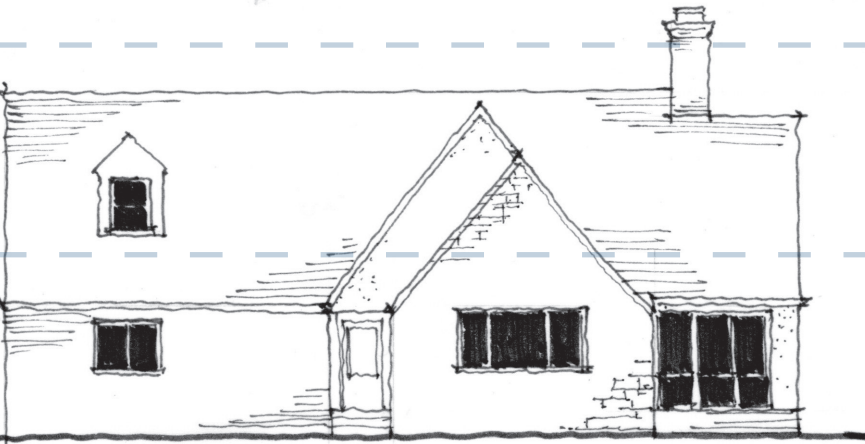

Floor-to-floor height



Average ridge height

Houses in this neighborhood reflect the later development of Pleasant Ridge / Francis Avenue, with the most common style being ranch houses. Note that the eave height and ridge height of a ranch house are similar to those of a Cape Cod, and that the floor-to-floor heights of

1½-story houses are still similar to those of a 2-story house. The ridge heights of the two houses to the right differ because the eave line of the ranch house is on the first floor.

# EUCLAIRE AVENUE PORCHES

## NEIGHBORHOOD HISTORY

In Bexley Plaza / Eastlawn / Livingston Heights, the frequency of front porches decreases from west to east. Houses on Euclaire and the first blocks of Montrose almost universally have porches, while the center-hall and Cape Cod houses further east generally do not.





Figure 16. Street section. Note the relatively shallow setbacks, which appear even shallower because of the front porches.





# HAVENWOOD PARK

## NEIGHBORHOOD HISTORY

Originally called Bexley Plaza, Havenwood Park is a small ellipse of green space containing a large number of mature trees. It is bordered by two curving streets, Havenwood Drive North and Havenwood Drive South. The latter is a brick street. All of the houses that front the park have driveway access from rear alleys, and several of the houses on the north face of the park have richly detailed features such as leaded windows and stone and brick accents. These same houses have rich, ornate interior woodwork and detailing that add to their charm.



Figure 17. Section through Havenwood Park from north (left) to south (right).

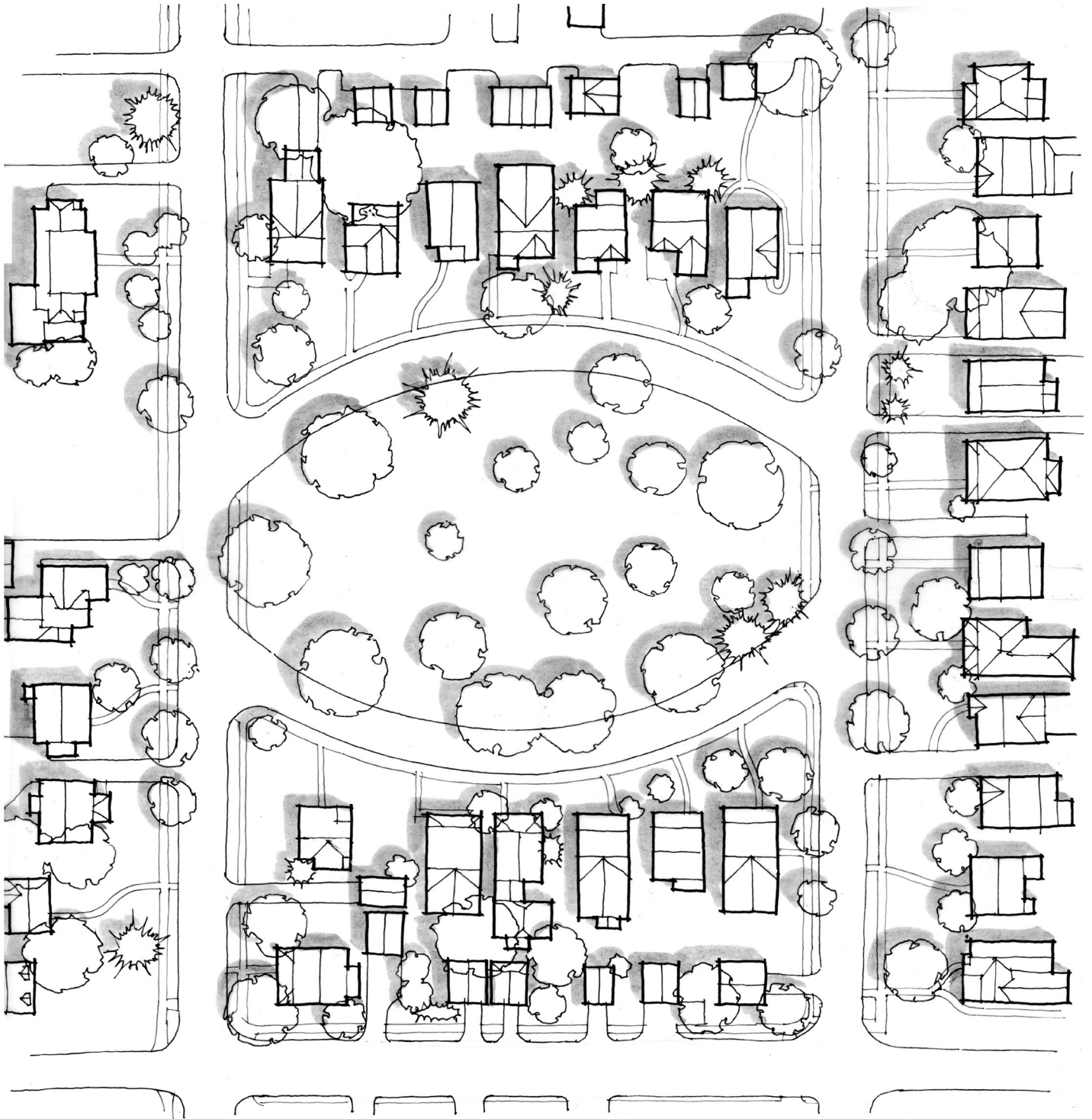

Figure 18. Plan of Havenwood Park.

# LIVINGSTON HEIGHTS TUDORS

## NEIGHBORHOOD HISTORY

The Tudor style is well represented in Bexley Plaza / Eastlawn / Livingston Heights, with the largest concentration along Montrose up from Livingston, including the celebration of corner lots along Charles with well-crafted Cotswold stone ranches and Tudor designs.



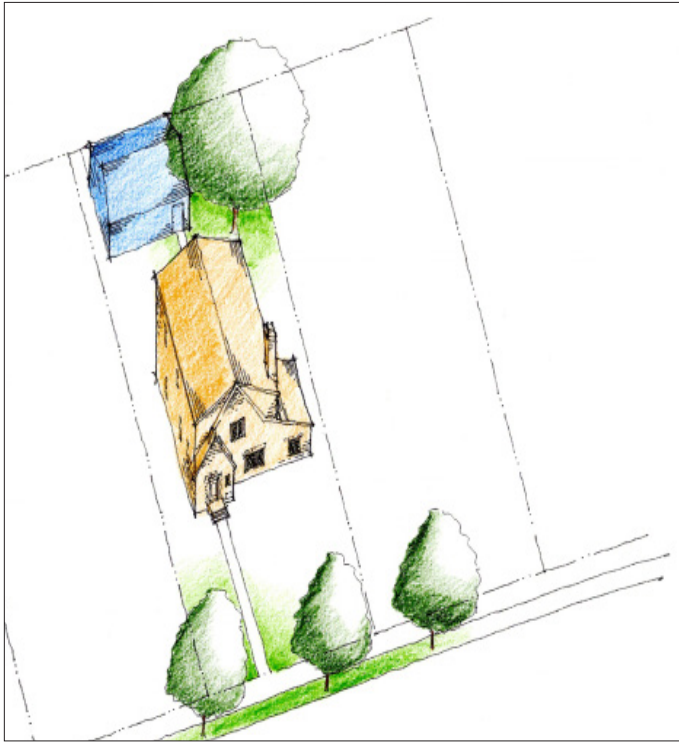

The drawing to the left shows a sample lot. Characteristics of note include the 50-foot lot width and slightly larger average setback throughout Livingston Heights (as opposed to the 40-foot lot width and slightly smaller average setbacks in Bexley Plaza and Eastlawn).

Figure 19. Sample lot.



# LIVINGSTON HEIGHTS TUDORS, CONT.

A. Tudors are the characteristic house type of this special character zone.

B. Porches are common in this neighborhood.

C. Garages tend to be detached, with entries from the alley.

D. The most common lot size is 50 feet wide and 135 feet deep (the same as the rest of Livingston Heights). The lot width may not allow for side additions. The average setback is approximately 50 feet from the street edge.

E. Other common house types include the 2- and 3-bay houses of the surrounding neighborhood.



Figure 20. Street aerial.

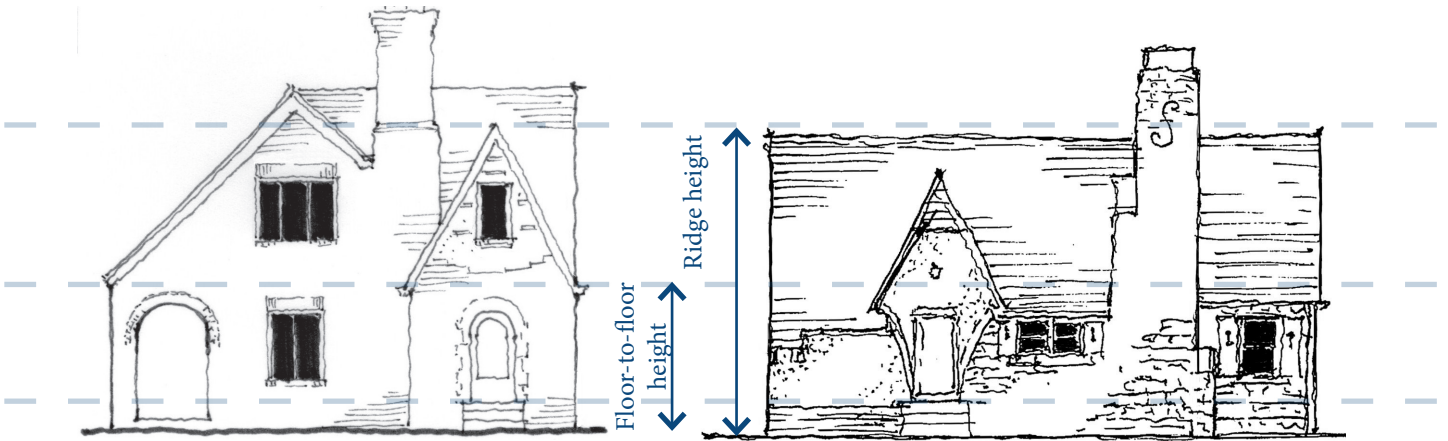

This neighborhood has a concentration of houses that reflect English design themes. Note that the ridge heights and floor-to-floor heights are similar (the house to the right has a half-story whose windows are on the sides).

# STANBERY

## NEIGHBORHOOD HISTORY

By the mid-1920s, single-family development spread across all parts of Bexley from north to south, and represented a much broader continuum of house prices to serve the burgeoning market. The Stanbery addition continued to serve the upper end of the market, and provided large lots for custom-designed houses. Carrying over the same attention to civic structure and English design themes, the Stanbery addition largely completed the demand for large, individually designed houses in Bexley.

Honor the original character of this area, which, like Bullitt Park, showcases individually designed houses on larger lots, a high degree of design consistency, a substantial character, use of rich materials, and design details.

Lot sizes in Stanbery are generally more uniform and smaller than in Bullitt Park, creating a more consistent contextual relationship. Rhythm between houses should be honored and preserved.





Figure 21. Typical street section. Note that the forest-like character of the street comes from mature trees in front yards (instead of from street trees, which are nonexistent due to the



Figure 22. Ashbourne Place section. Note the shallower setbacks compared to the rest of the neighborhood.





# STANBERY, CONT.

The drawing to the left shows a sample lot. Characteristics of note include deep setbacks, wide lots with potential for side additions, and a front driveway. The example to the left shows a detached garage; however, attached garages are also very common.



Figure 23. Sample lot.

Houses in this neighborhood reflect a variety of styles, from Georgian to Tudor. Note that even across styles, the floor-to-floor heights, eave heights, and ridge heights are similar.



A. Common house types include 5-bay houses (symmetrical or asymmetrical) and Tudor-style houses.

B. Porches are not as common here as in other neighborhoods.

C. Garages tend to be attached, though there are detached garages. Due to the absence of alleys, entry is from a front driveway (with the exception of some houses on Ashbourne Road, which have access to their garages from Cassady Avenue).

D. Lot sizes and setbacks vary, especially at Ashbourne Place. The most common lot has a width of 90 feet and a depth of 160 or 172 feet. The lot width may allow for side additions. Setbacks vary widely, averaging 75 feet from the street edge.

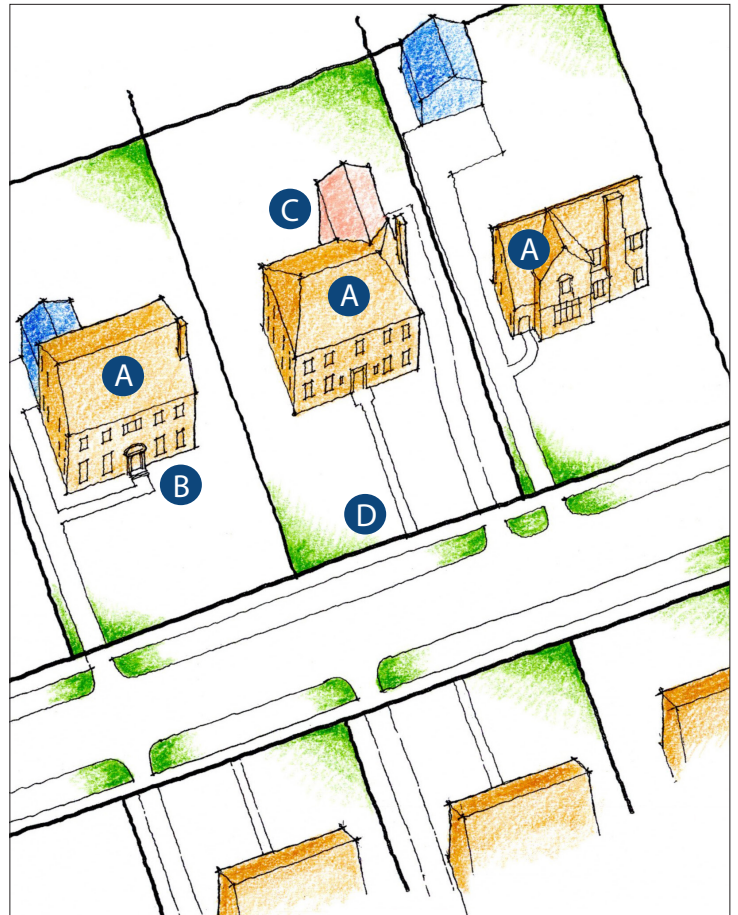

Figure 24. Street aerial.



# ARDMORE NORTH & SOUTH

## NEIGHBORHOOD HISTORY

As eastward development approached Cassady Avenue, a clear north-south line through north and Central Bexley. Housing dramatically changed from individually designed and built homes on large lots to builder-developed and designed homes on smaller lots. By the mid-1920s, the Broad St carriage lanes were removed, and, beginning eastward from Cassady Avenue, an alley system was put in place to provide appropriate spots for utility poles and trash pickup.

Builder houses continued to provide a broad array of house styles that reflected traditional themes: cottages, Dutch colonial, Georgian center hall, Tudor variations, and others. The incorporation of front and side porches, sunrooms, detached garages, and single-car driveways became the norm. A uniform massing was achieved by uniform front and side yards and by the dominant two-story heights of the houses.

As the larger lot areas transitioned to smaller, more uniform, narrower lot sizes, a more urban streetscape was created. A sense of shared front yard green space is established, creating a generally continuous building face, which in turn frames a shared civic space containing the street, tree lawns and street trees, and front yards. This feature is accentuated by long north-south block faces, creating a strong visual perspective north and south.

Unlike houses in Bullitt Park, whose

larger and wider front facades provide more area for design features unique to specific styles of architecture, houses in Ardmore North and South have smaller facades with less area available for such features. Facades are sometimes limited to celebrating the front door, a porch, window treatments, or a chimney on the front as opposed to the side.

In general, each street in Ardmore North and South has its own unique character and composition. Streets like S Ardmore and S Cassingham contain slightly larger houses with more use of 1920s-style details and more use of brick than wood frame construction. N Cassingham contains more Dutch colonial style homes, while N Roosevelt has rows of smaller, largely identical, two-story center-hall houses. Tudor-style houses with their dominant front-facing gables are more present in the western streets, while later eastern streets show more consistent use of stone accents, stucco, and brick on both two-story and ranch-style homes. The influence of generally larger houses along Fair Avenue also led to larger, more expensive houses on the first block north along intersecting streets in Ardmore South.



Figure 25. Typical street section.

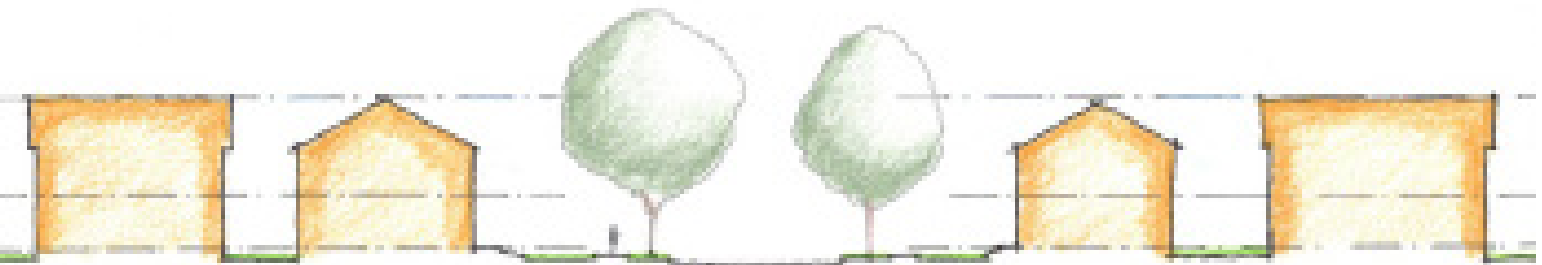

Figure 26. Cross-street section. Note that both houses shown have their front entries on the cross-street.

# ARDMORE NORTH & SOUTH, CONT.

The drawing to the left shows a typical lot. Characteristics of note include the setback, a lot width not likely to accommodate side additions, and a detached garage with access from the alley.

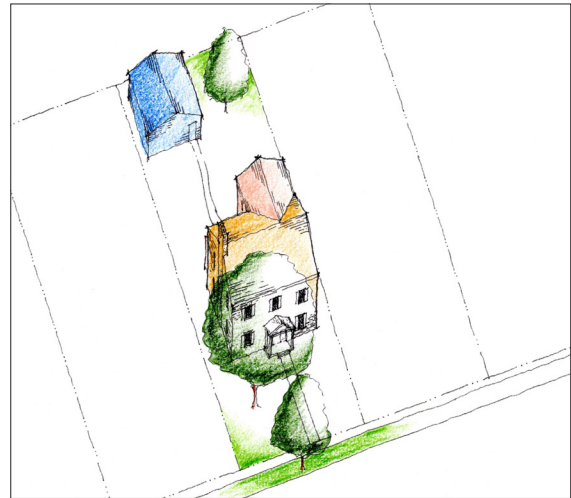
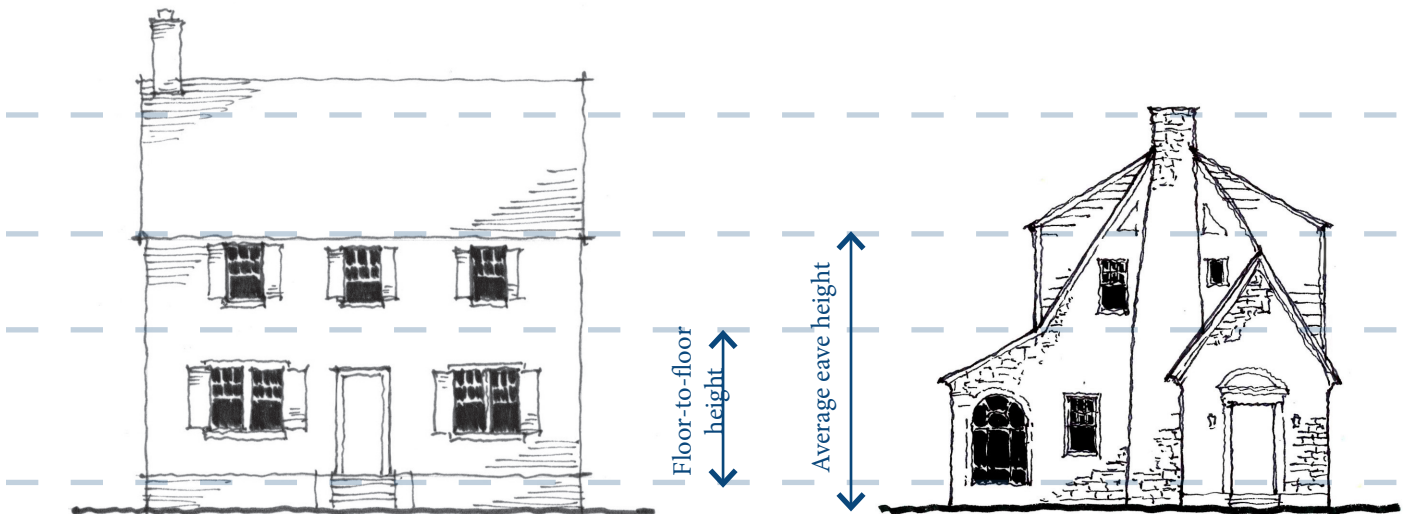

Figure 27. Typical lot.



Houses in this neighborhood reflect a wide variety of styles at very similar scales. Across styles, the floor-to-floor heights, eave heights, and ridge heights are similar. Unlike houses in Bullitt Park, whose larger and wider front facades provide more area for design features unique to specific styles of architecture, houses in Ardmore North and South have smaller facades with less

area available for such features. Facades are sometimes limited to celebrating the front door, a porch, window treatments, or a chimney on the front as opposed to the side.

In general, each street in Ardmore North and South has its own unique character and composition. Streets like S Ardmore and S Cassingham contain slightly larger

- A. The most common house type is a 3-bay house (symmetrical or asymmetrical).
- B. Porches are common in this neighborhood.
- C. Garages tend to be detached, though there are attached garages. Access is from the alley. If there is no alley, access is from a front driveway.
- D. The most common lot is 50 feet wide and 142 feet deep. The average setback is approximately 65 feet from the street edge.
- E. Other common house types include large bungalows.
- F. Houses on corner lots may have front entries on the cross-street. Garages on corner lots tend to have entries on the cross-street instead of on the alley. Depending on the orientation of the house, corner lots may be able to accommodate side additions instead of rear additions.



Figure 28. Street aerial.

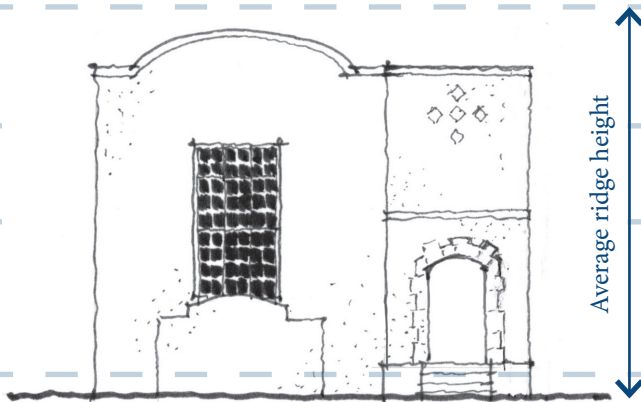

houses with more use of 1920s-style details and more use of brick than wood frame construction. N Cassingham contains more Dutch colonial style homes, while N Roosevelt has rows of smaller, largely identical, two-story center-hall houses. Tudor-style houses with their dominant front-facing gables are more present in the western streets, while later eastern streets

show more consistent use of stone accents, stucco, and brick on both two-story and ranch-style homes. The influence of generally larger houses that were constructed along Fair Avenue also led to larger, more expensive houses on the first block north along intersecting streets in Ardmore South.

# ARDMORE EAST-WEST STREETS

## NEIGHBORHOOD HISTORY

The drawing below shows a typical lot. Characteristics of note include the shallow setback (compared to the average setback of the rest of Ardmore) and a front driveway that may cross the property line (and may be shared with a neighboring lot).



Figure 29. Sample lot.



**A.** Common house types include 3-bay houses and their asymmetrical equivalents.

**B.** Porches are very common in this neighborhood.

**C.** Garages tend to be detached. Due to narrow lots and the absence of alleys, access is from a front driveway that may be shared with a neighboring lot.

**D.** Lot widths are fairly uniform at 50 feet. Lot depths vary from 122 feet to 135 feet. The average setback is approximately 45 feet from the street edge.

**E.** Other common house types include



Figure 30. Street aerial.



Figure 31. Typical street section. Note the porches, shallow setbacks, and overall compact arrangement.





# MERKLE ROAD STONEWORKS

## NEIGHBORHOOD HISTORY

The facade designs of Bexley houses have consistently utilized the use of stone, from Bexley's earliest development to its most current new home construction, reflecting its timeless appeal. Within all of Bexley's development areas, the most consistent use of stone can be seen on N Merkle, with 30 smaller Cape Cod style houses having partial or total stone facades. Together, these houses reflect a cohesiveness and uniformity which differentiates them from neighboring Cape Cod houses both on N Merkle and the streets further east in the City of Columbus.



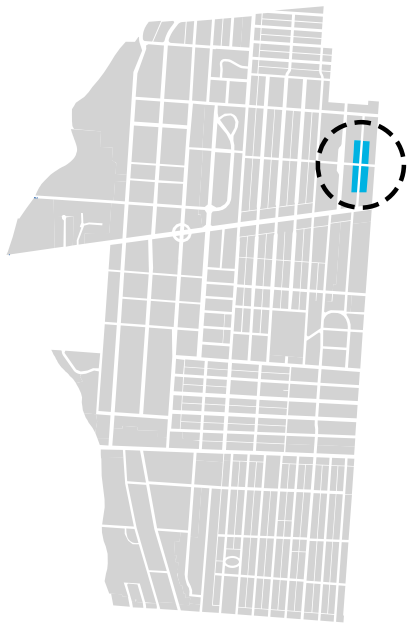

# MERKLE ROAD STONEWORKS, CONT.

The drawing to the right shows a typical lot. Characteristics of note include the compact arrangement of elements, the shallower setback (compared to the rest of Ardmore), the garage oriented parallel to the street, and the front driveway due to the absence of alleys.

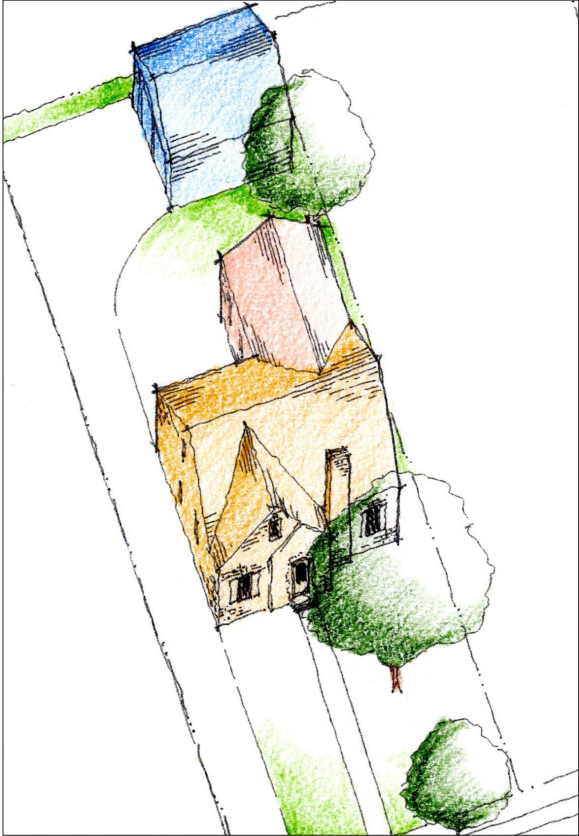

Figure 32. Typical lot.

Houses in this neighborhood are noted for their stone facades. The Cape Cods, the most common type, have only slight variations in composition, and as such have very similar floor-to-floor heights, eave heights, and ridge heights. Though not drawn, there are other house types in this neighborhood that have stone facades, such as ranch houses and post-war 3-bay houses.



- A.** The characteristic house type in this special character zone is a Cape Cod, symmetrical or asymmetrical.
- B.** Porches are not as common here as in other neighborhoods.
- C.** Garages tend to be detached. Due to the absence of alleys, access is from a front driveway.
- D.** The most common lot is 50 feet wide by 134 feet deep. The average setback is approximately 50 feet from the street edge.
- E.** Other common house types include 3-bay, 2-story houses.

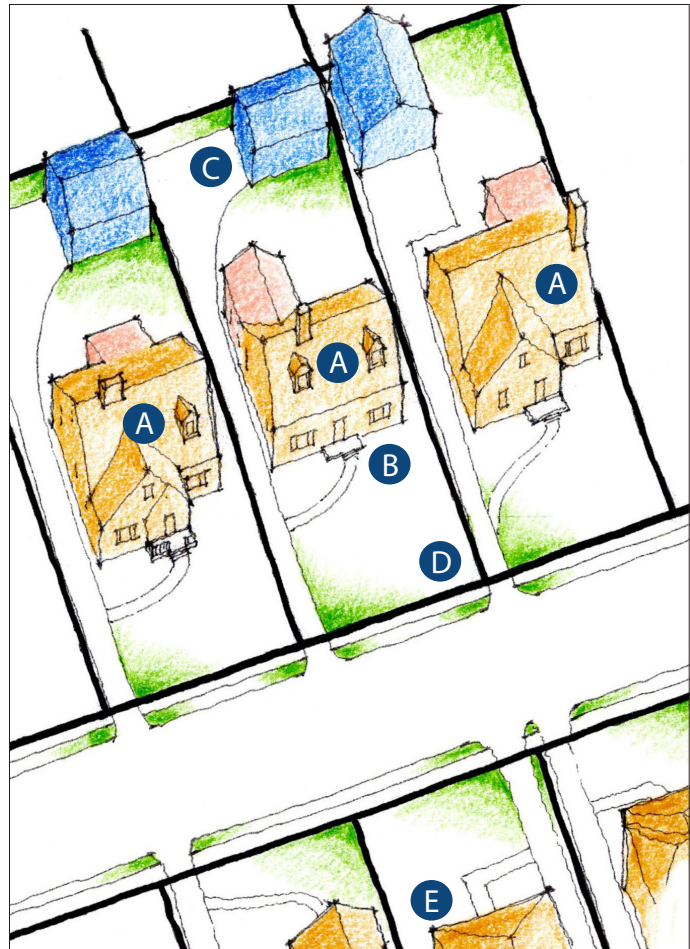
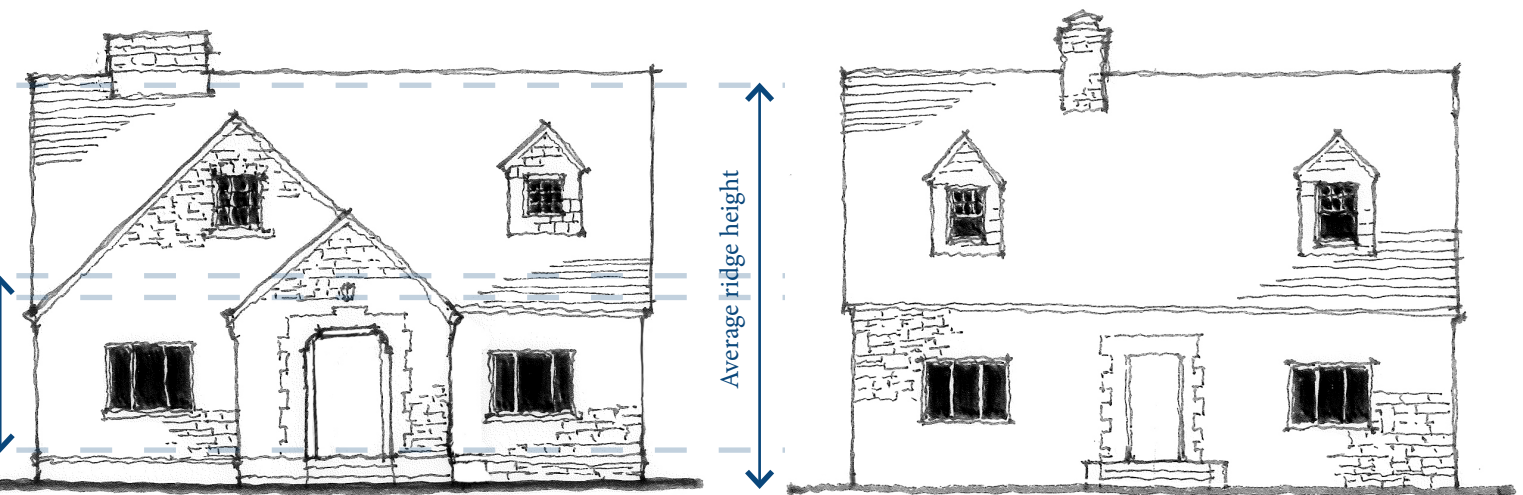

Figure 33. Street aerial.



# ARDMORE 1950'S

## NEIGHBORHOOD HISTORY

In the early 1930s, the Great Depression brought the housing boom of the 1920s to a standstill, leaving pockets of developed but vacant lots throughout Bexley, especially in Ardmore North and South, Bexley Plaza / Eastlawn / Livingston Heights, and Bellwood. As development moved from west to east, the number of unsold or undeveloped lots increased substantially, leaving in the west many individual lots for later infill, and in the east whole tracts of vacant ground. Not until the late 1940s and early 1950s did single-family development resume, notably at the eastern

edge of Bexley. Almost thirty years had passed, and housing preferences had shifted from more traditional, two-story houses with detached garages to more modern, one-story houses with attached garages. These newer house designs reflected the use of different materials, different roof shapes, more horizontal forms, and simplified details. Though they are concentrated on the east side of Ardmore North and South, houses built on more westerly infill lots also followed this trend.





Figure 34. South Merkle Road section north of Powell.



Figure 35. South Merkle Road section south of Powell. Note the shallower setbacks.



## ARDMORE 1950'S, CONT.

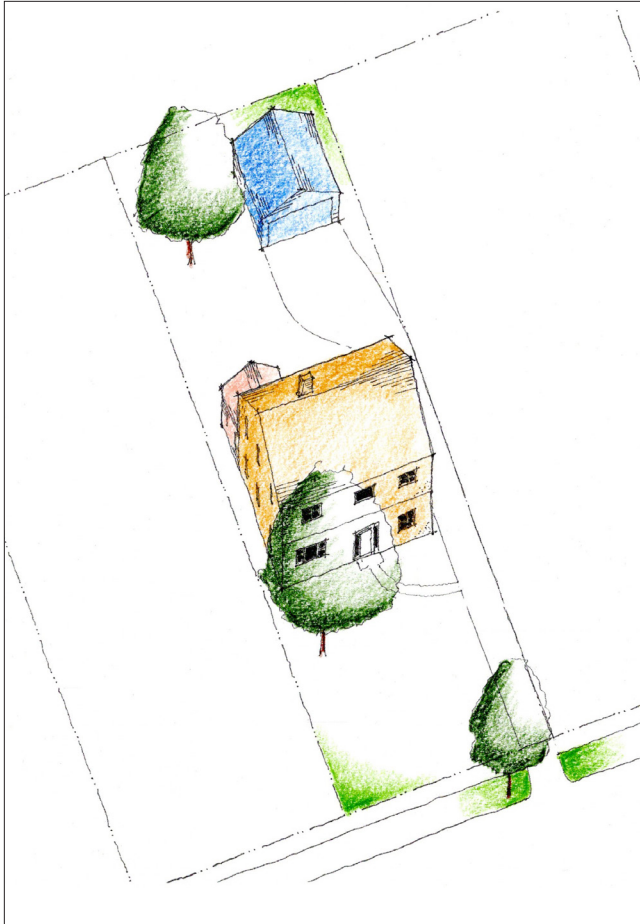

Figure 36. Sample lot.

The drawing to the left shows a sample lot. Characteristics of note include the relatively deep setback (compared to the rest of Ardmore) and the front driveway, present due to the absence of an alley.

Houses in this neighborhood reflect the later development of the east side of Bexley and tend to be one-story ranch houses or post-war 3-bay houses. These houses illustrate trends in post-war residential design: a greater emphasis on horizontality, wider windows, corner windows, hipped roofs instead of gable roofs, and simplified details. Floor-to-floor heights, eave heights, and ridge heights are not comparable across the two houses illustrated, but these heights in ranch houses tend to be similar, as do the heights in post-war 3-bay houses.



**A.** The characteristic house types of this special character zone are ranch houses and post-war 3-bay houses (which are wider and deeper than pre-war 3-bay houses).

**B.** Porches are not as common here as in other neighborhoods.

**C.** Garages tend to be attached, though there are detached garages. As there are no alleys, access is from a front driveway.

**D.** Lot sizes vary. Most lots have a width of 60 or 65 feet and a depth of 180 or 200 feet. The average setback is approximately 70 feet from the street edge; however, the setbacks of houses located south of Powell Street tend to be smaller than the setbacks of houses located north of Powell Street.

**E.** Other common house types include houses from the 1970s and later.

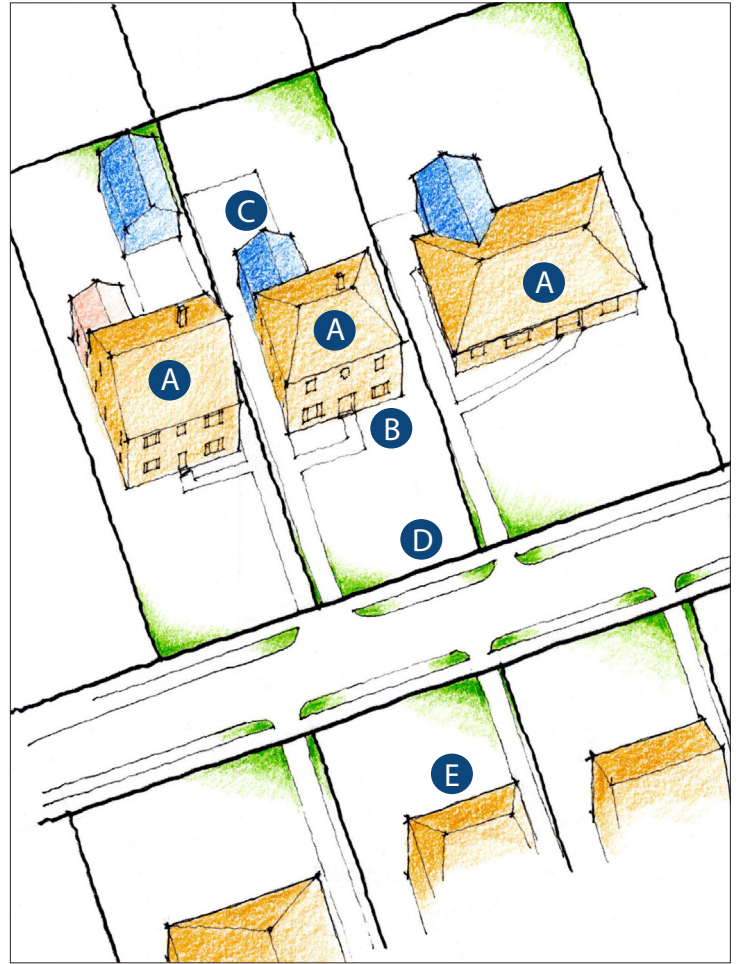

Figure 37. Street aerial.





# BEXLEY PARK / RUDOLPHS FAIRWOOD / BEXLEY HIGHLANDS

## NEIGHBORHOOD HISTORY

For the area east of Drexel and between Fair and E Main St, a design decision was made to break away from the standard north-south street grid and to establish an east-west street grid, and to establish special boulevard streets, hence the “Boulevard District.” Cassady Avenue between Fair and Main was also originally a boulevard, but the median was later removed. The Boulevard District continued the use of alleys and provided a variety of lot widths to accommodate larger houses that did not fit on a standard 50-ft-wide lot. Many custom-designed,

unique houses are within this district.

The Boulevard District contains generally uniform east-west block faces that are smaller in length, providing for more corner lots with larger yard areas. Unlike Ardmore North and South, the Boulevard District has a mix of lot sizes and widths, and contains an array of house sizes from estate-size to more traditional house sizes found in Ardmore North and South. The eastern end of the Boulevard District has larger block faces.

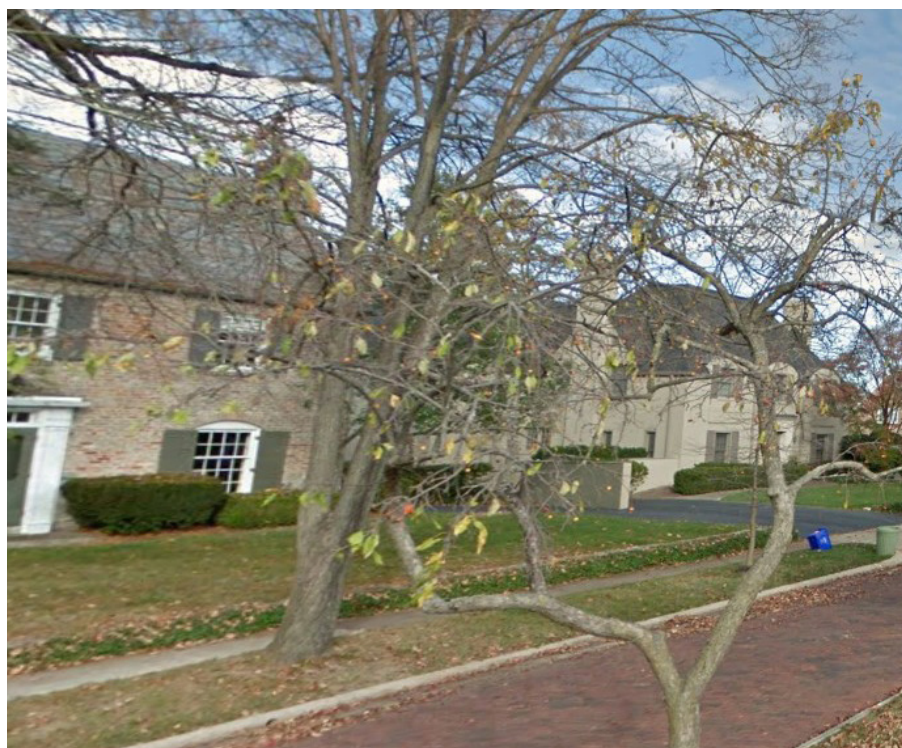
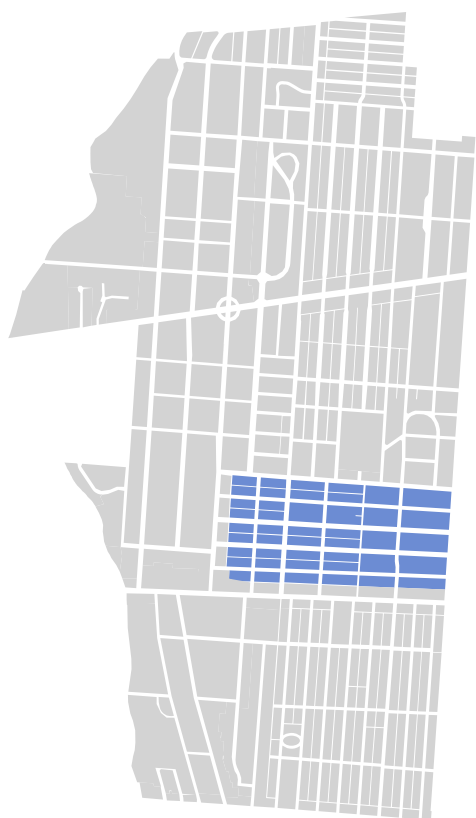



Figure 38. Typical street section. Note the trees that give the boulevards their character.



Figure 39. Typical cross-street section.



Figure 40. Street section without median. Note that the street trees have large canopies.



# BEXLEY PARK / RUDOLPHS FAIRWOOD / BEXLEY HIGHLANDS

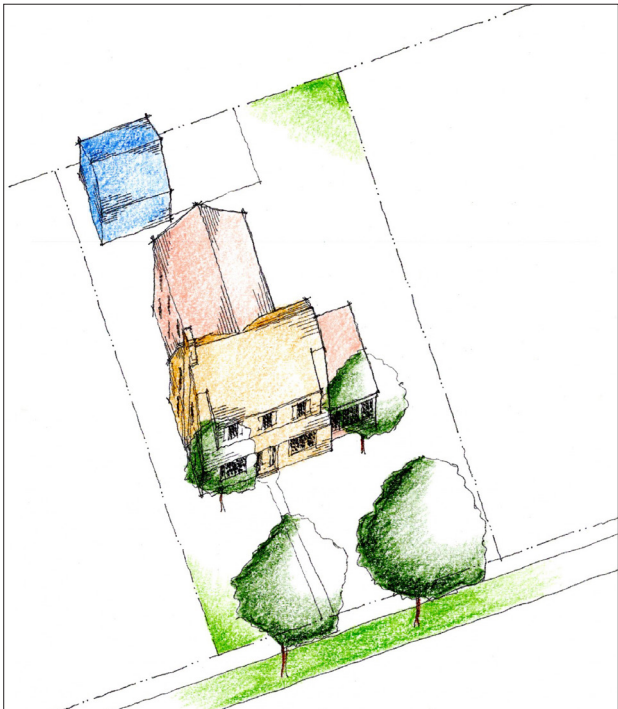

Figure 41. The drawing above shows a sample lot. Characteristics of note include a garage accessed from the alley (if present) and a lot width that may allow for side additions

- A.** The most common house types are 3-bay houses (symmetrical or asymmetrical).
- B.** Porches are common in this neighborhood.
- C.** Garages tend to be detached. For lots that have alleys, access is from the alley. For lots that do not have alleys (see Figure 2), access is from a front driveway.
- D.** Lot widths range from 50 feet to 100 feet. Lot depths are an average of 140 feet. The average setback is approximately 70 feet from the street edge.
- E.** Other common house types include 5-bays (on larger lots only) and post-war 3-bays (mostly on the east side of the neighborhood).

**F.** Corner lots may be larger than other

Houses in this neighborhood reflect a wide variety of styles. Note that across house styles, the floor-to-floor heights, eave heights, and ridge heights are comparable. The Modernist house (second from the right) has a slightly lower

second-floor level due to the modern preference for lower ceilings, and the ridge height is not applicable, but its eave is still at a height comparable to the eaves of the more traditional houses.



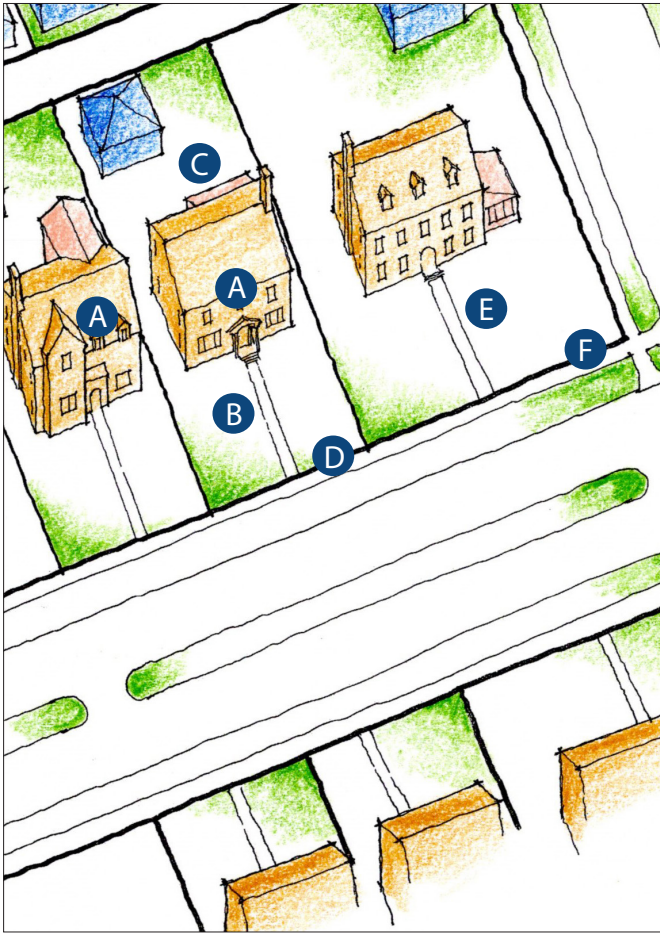

Figure 42. Street aerial with alleys.

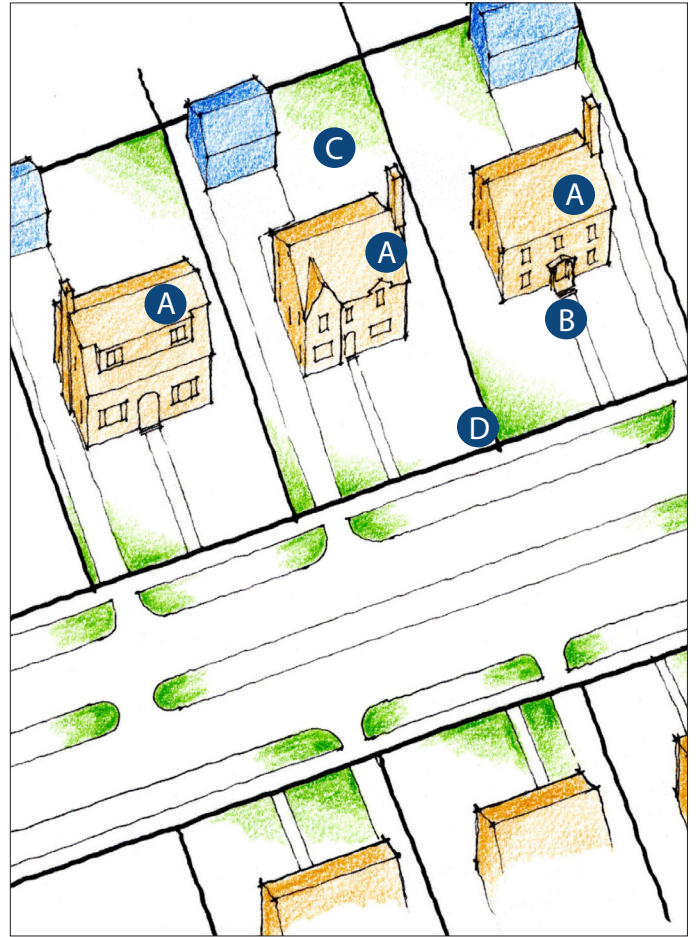
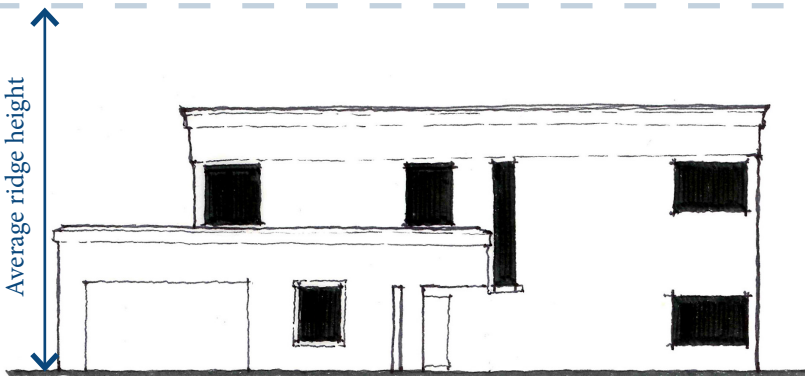

Figure 43. Street aerial without alleys.



# BELLWOOD

## NEIGHBORHOOD HISTORY

The postwar-era “baby boom” created a need for smaller, more inexpensive housing. The remaining undeveloped areas along the north edge of Bexley were then utilized for rows of Cape Cod and other smaller housing styles to meet this emergent need.

This district with its east-west grid, like Bexley Park / Rudolphs Fairwood / Bexley Highlands, is another deviation from Bexley’s dominant north-south grid. It provided frontage and access

for corner lots on N Cassady for multi-family and non-residential uses. In an area north of Caroline Avenue, a transition occurred between larger lots to the south to smaller lots to the north, as house sites developed nearer to the railroad tracks.

Honor the size and uniformity of the dominant Cape Cod style by avoiding oversized dormers or two-story additions.



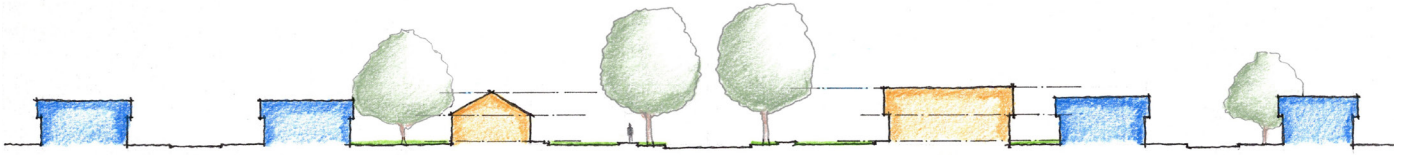

Figure 44. Typical street section.



Figure 45. Cross-street section.



# BELLWOOD, CONT.

The drawing to the left shows a sample lot. Characteristics of note include the shallow setback and the compact arrangement of elements.

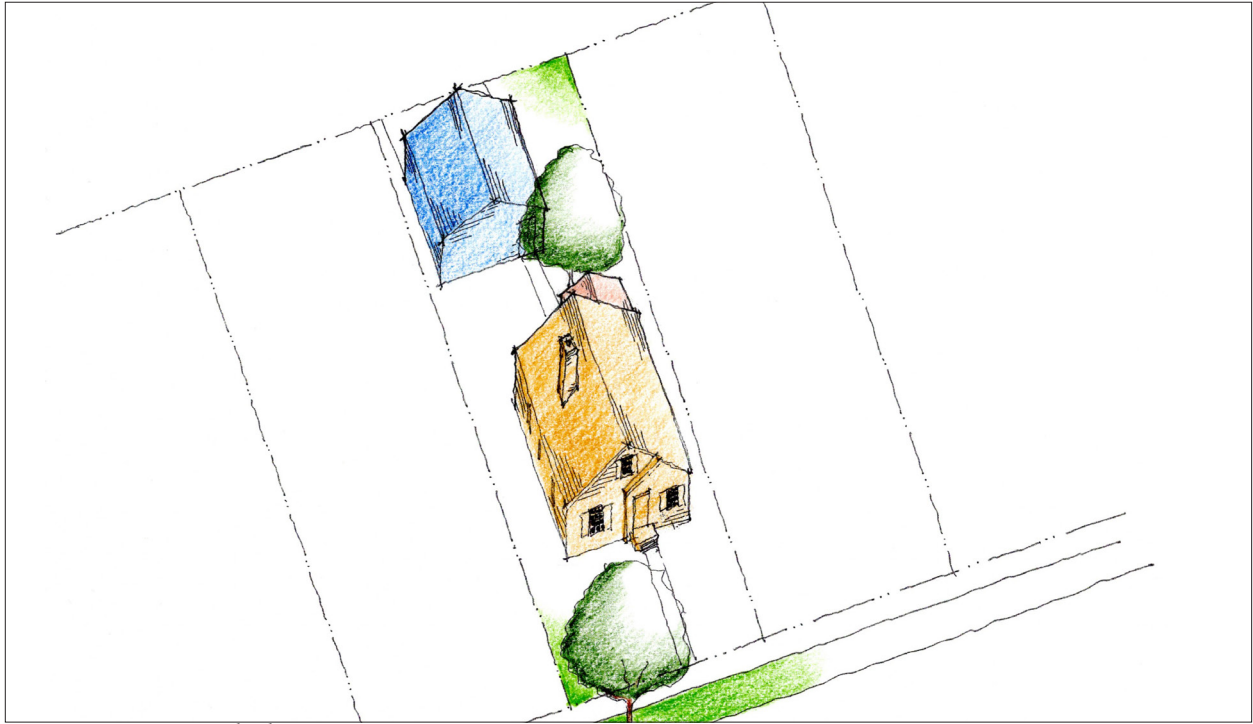

Figure 46. Sample lot.



Houses in this neighborhood reflect the need for smaller, more affordable housing after World War II. The Cape Cods are fairly uniform in style, though some may have more elaborate entry details

or porches that set them apart. Also of note are a few farmhouses, which reflect an older style of houses that preceded the Cape Cods.

**A.** The most common house types in this neighborhood are Cape Cods (asymmetrical and symmetrical).

**B.** Porches are common in this neighborhood.

**C.** Garages tend to be detached. Access is from the alley. Not all houses have a garage.

**D.** The most common lot size is 40 feet wide by 120 feet deep. The average setback is approximately 40 feet from the street edge.

**E.** Other common house types include farmhouses.

**F.** Corner lots are the same size as other lots on the block. Front entries tend to be on the front street rather than the cross-street. Regardless of the orientation of the front entry, access to the garage tends to be from the cross-street.

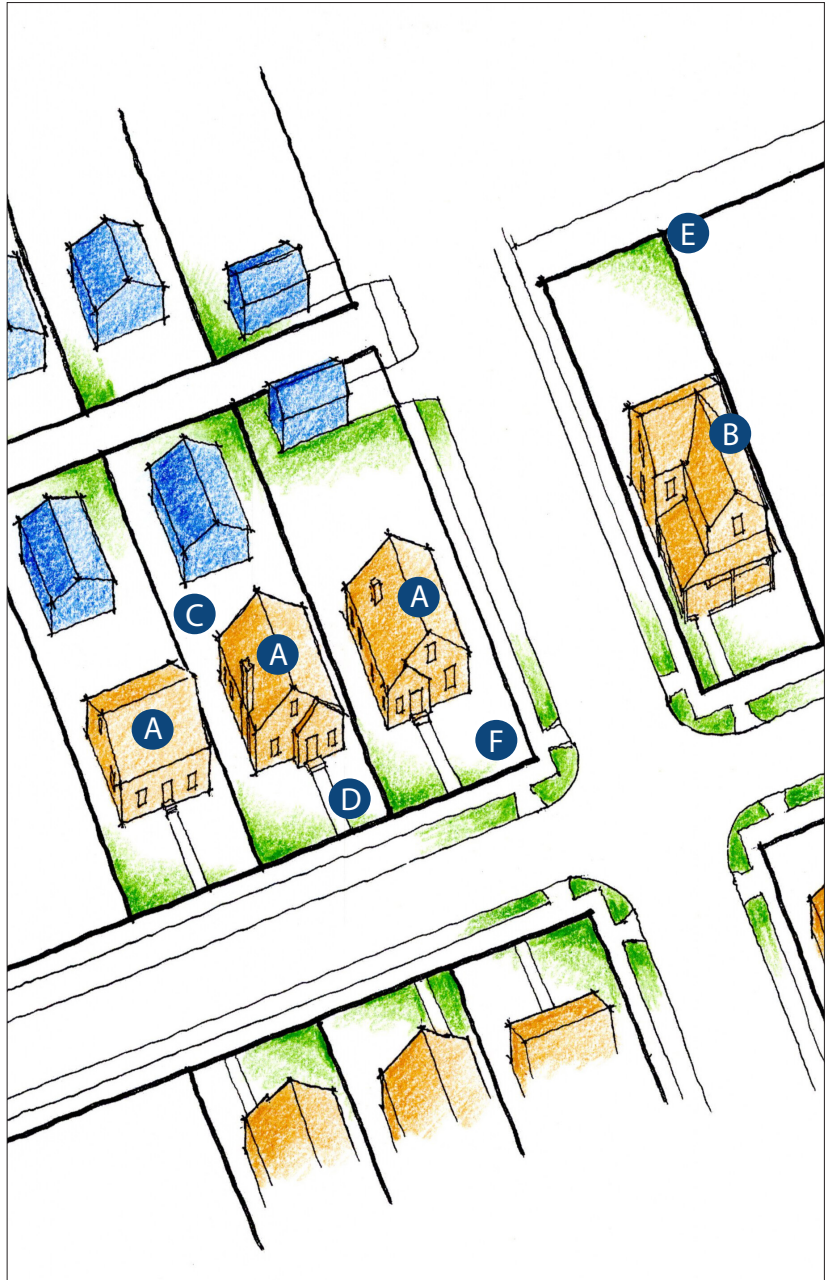

Figure 47. Street aerial.



# NEW BUILD GUIDELINES



Figure 48. Typical street with proposed new build contemporary house.



Figure 49. Typical street with proposed new build contemporary house.



Figure 50. Typical street with improper new build house.

Improper details for Bexley

No clear hierarchy of massing or main entry

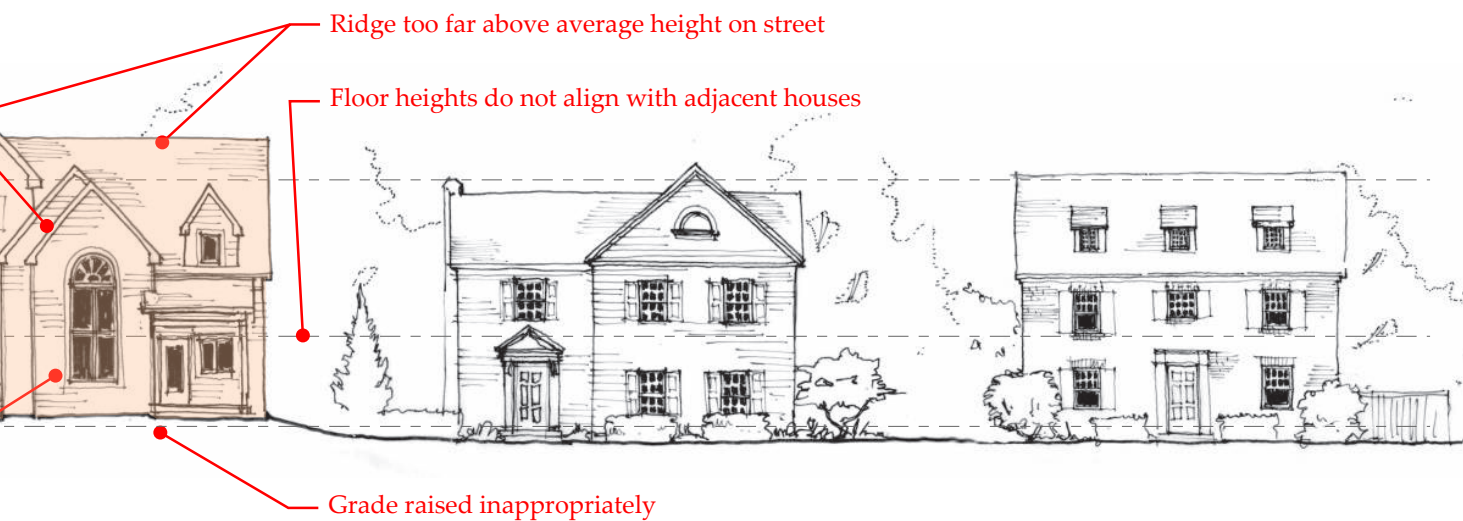
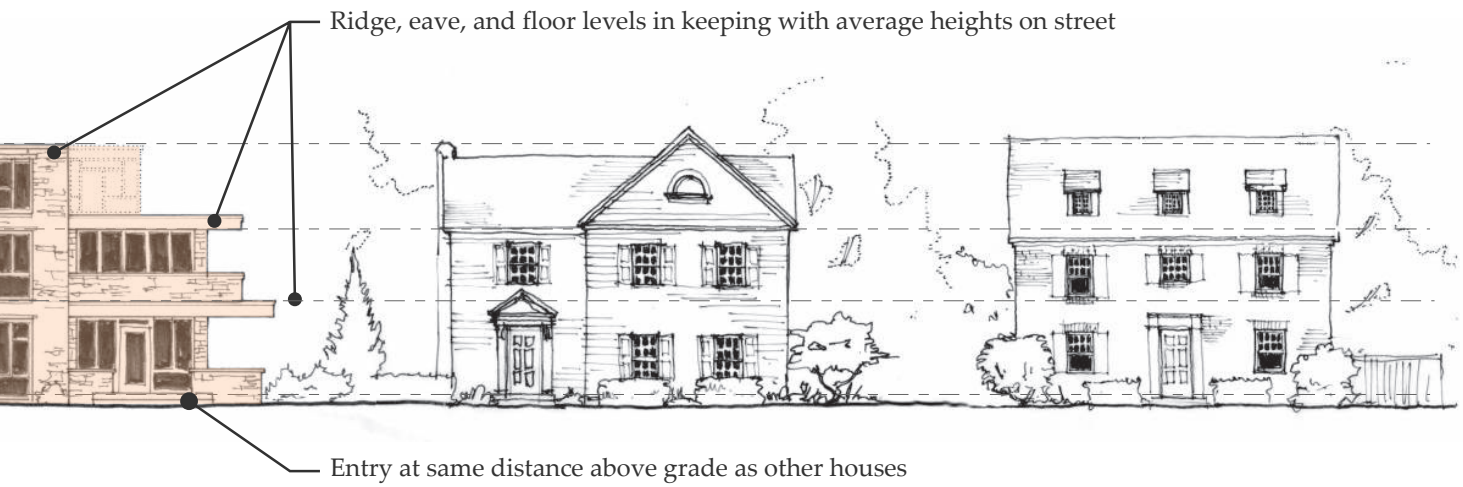

# INAPPROPRIATE ADDITIONS

Addition oversized on original house. Existing house should be dominant massing

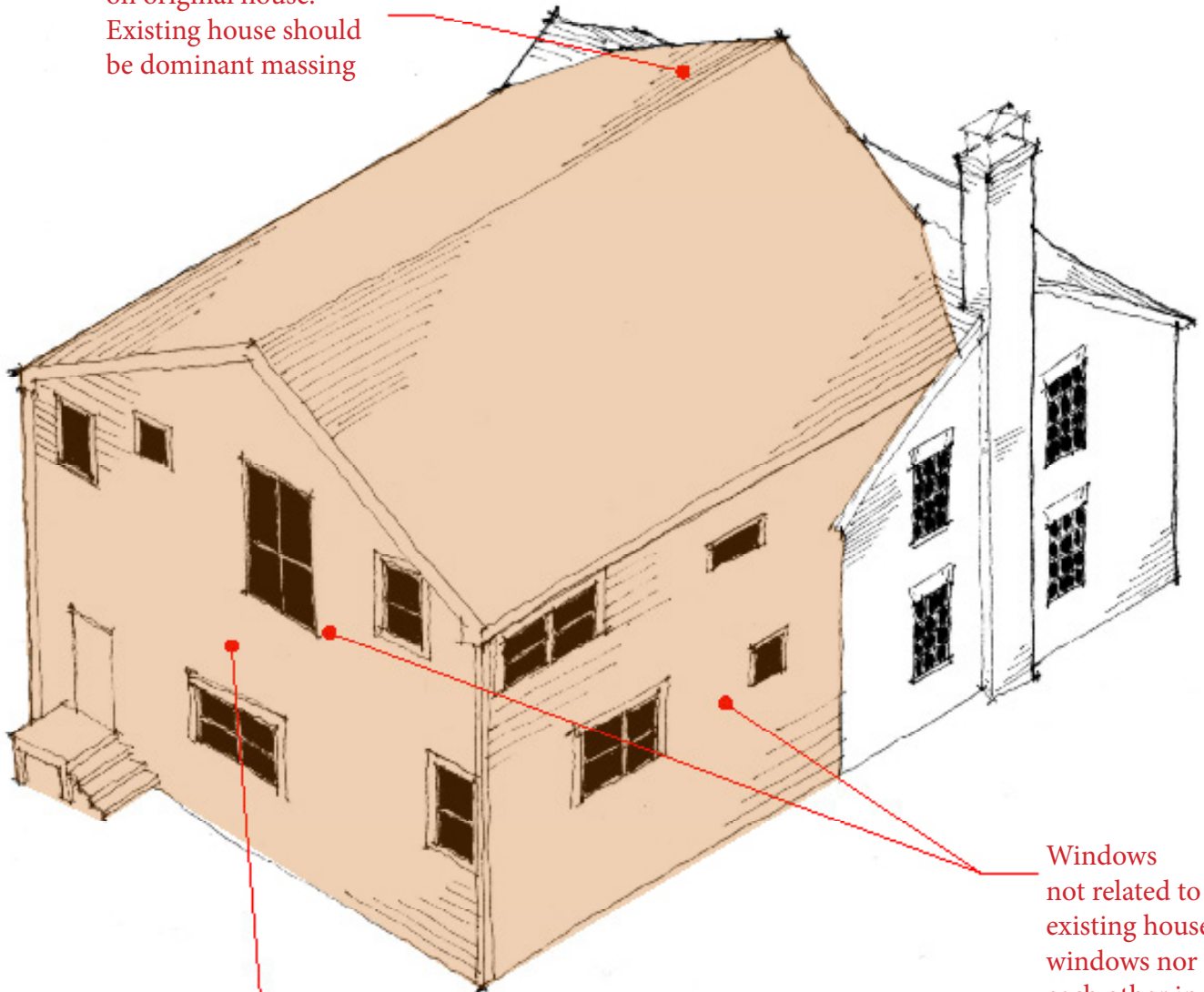

Windows not related to existing house windows nor to each other in a coherent manner

Rear gable elevation oversized for lot and massing of original house. Windows not related to each other in a coherent manner

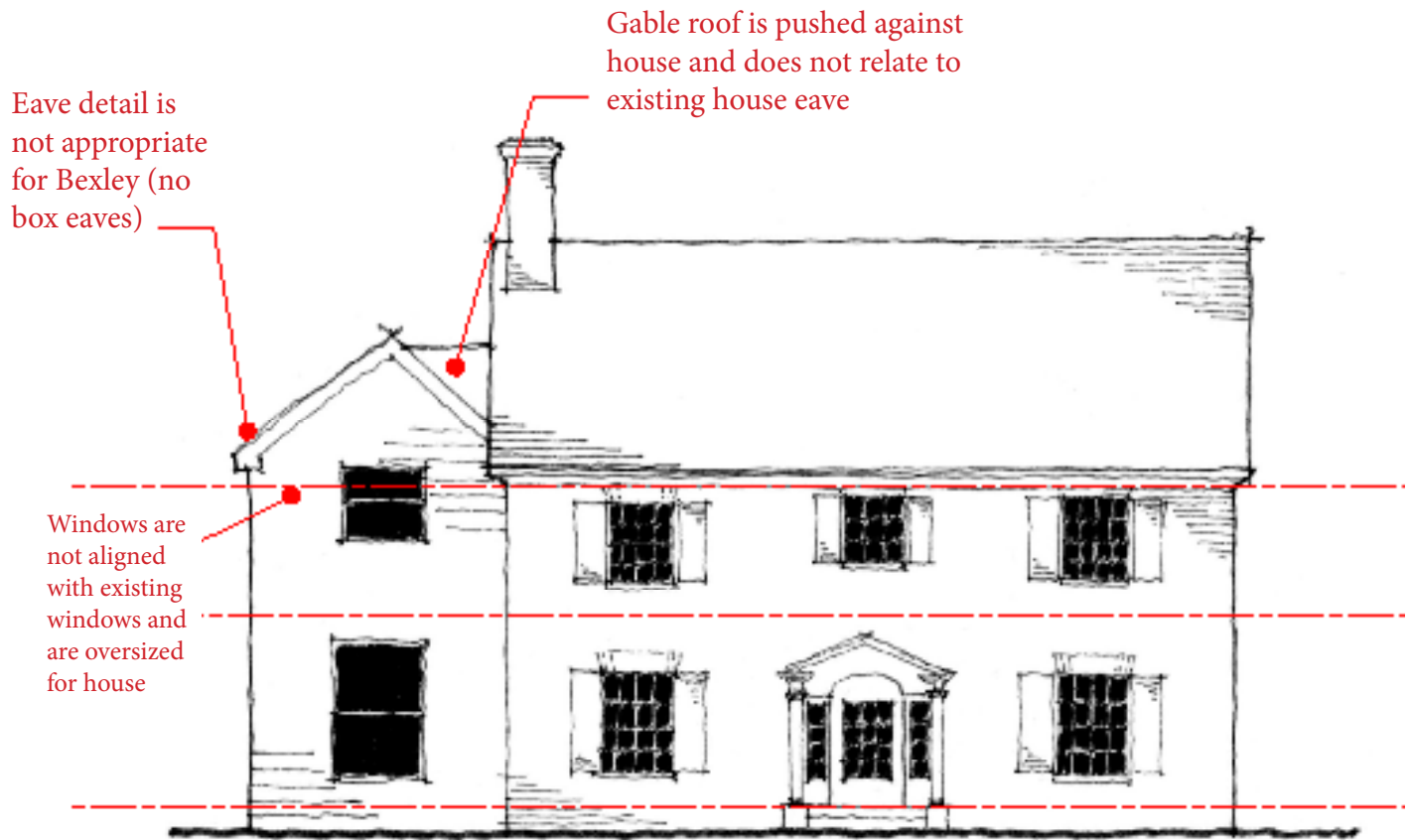

# HOUSE DETAILS: 3-BAY

2-story, 3-bay house with clapboard siding, painted wood porch, and asphalt shingle roof. Note overall smaller scale compared to houses in other neighborhoods. Vegetation lines the front.

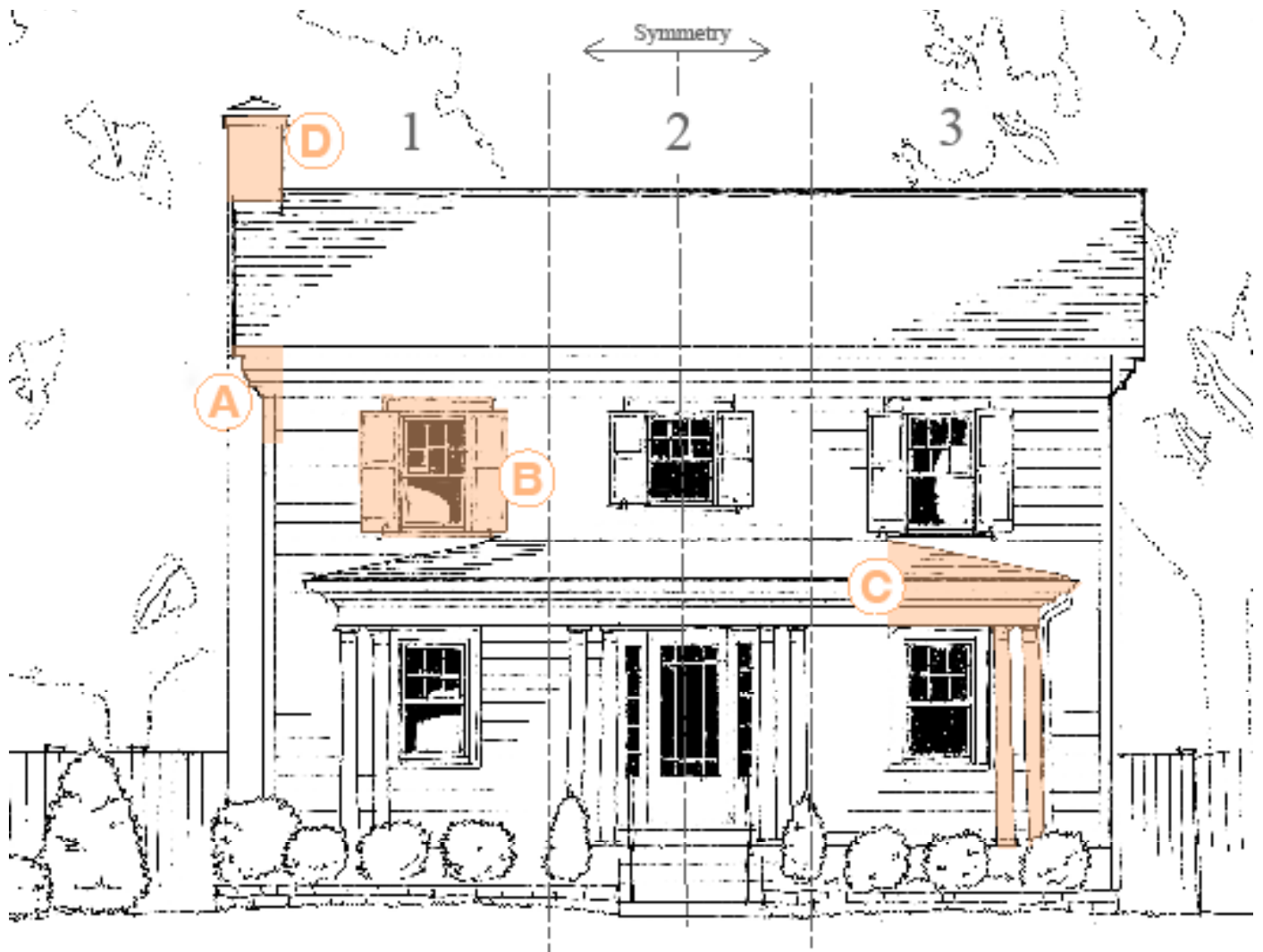

**A. EAVE:** The length of the main roof eave overhang is equivalent to the height of the fascia and the frieze board. For more information on eaves, see pages 90-95.

**B. WINDOW:** Note use of shutter dogs and alignment of shutters with window head and sill. The window lite/muntin configuration is 6 over 1. Lites have a vertical (2:3) proportion. Windows align with other architectural elements both horizontally and vertically. Windows do not have “picture frame” casings. Casing and sills align with clapboard siding. For more window details, see pages 104-109.

**C. PORCH:** The porch is raised, as is typical for the neighborhood. Attenuated columns are acceptable; paired columns provide more visual support for the porch roof than single attenuated columns do. For more porch details, see pages 96-103.

**D. CHIMNEY:** For chimney examples, see pages 70-71.

# HOUSE DETAILS: BUNGALOW

2-story, 3-bay house with clapboard siding, painted wood porch, and asphalt shingle roof. Note vegetation across the front. Note overall smaller scale compared to houses in other neighborhoods.



**A. CHIMNEY:** For more chimney examples, see pages 70-71.

**B. DORMER:** Shed dormer with two pairs of double-hung windows. Note that the proportion of the individual windows is 2:3 and the proportion of the window pairings is 3:2. Each window has a 6-over-6 lite/muntin pattern. The shed roof meets the main roof at or below the ridge. For more window and dormer details, see pages 110-115.

**C. PORCH:** 2 round Tuscan porch columns. Note that the proportion of the porch openings between the columns and end piers is 2:3. For more porch and column details, see pages 96-103.

# HOUSE DETAILS: 3-BAY

3-story, 3-bay house with brick veneer, painted wood porch, and asphalt shingle roof. Note that the windows and doors maintain horizontal and vertical alignment. Vegetation lines the front.



A. CHIMNEY: For more chimney examples, see pages 70-71.

B. WINDOW: The top and bottom of the shutters align with those of the window opening. The width of each shutter is equal to half of the window. The lite/muntin configuration is 8 over 8. The example shows brick lintels and sills. For more window details, see pages 104-109.

C. PORCH: Tuscan columns and entablature with low-slope roof. The extents of the porch align with the 3-bay division.

D. Note that the dormers' double casement windows have the same proportion (2:3) as the windows below. The dormer roof pitch is less than 12:12. For more dormer details, see pages 110-115.

# HOUSE DETAILS: 3-BAY ASYMMETRICAL

3-story, 3-bay house with clapboard siding and slate roof. The overall composition is asymmetrical, but there is local symmetry. Note vegetation across the front.

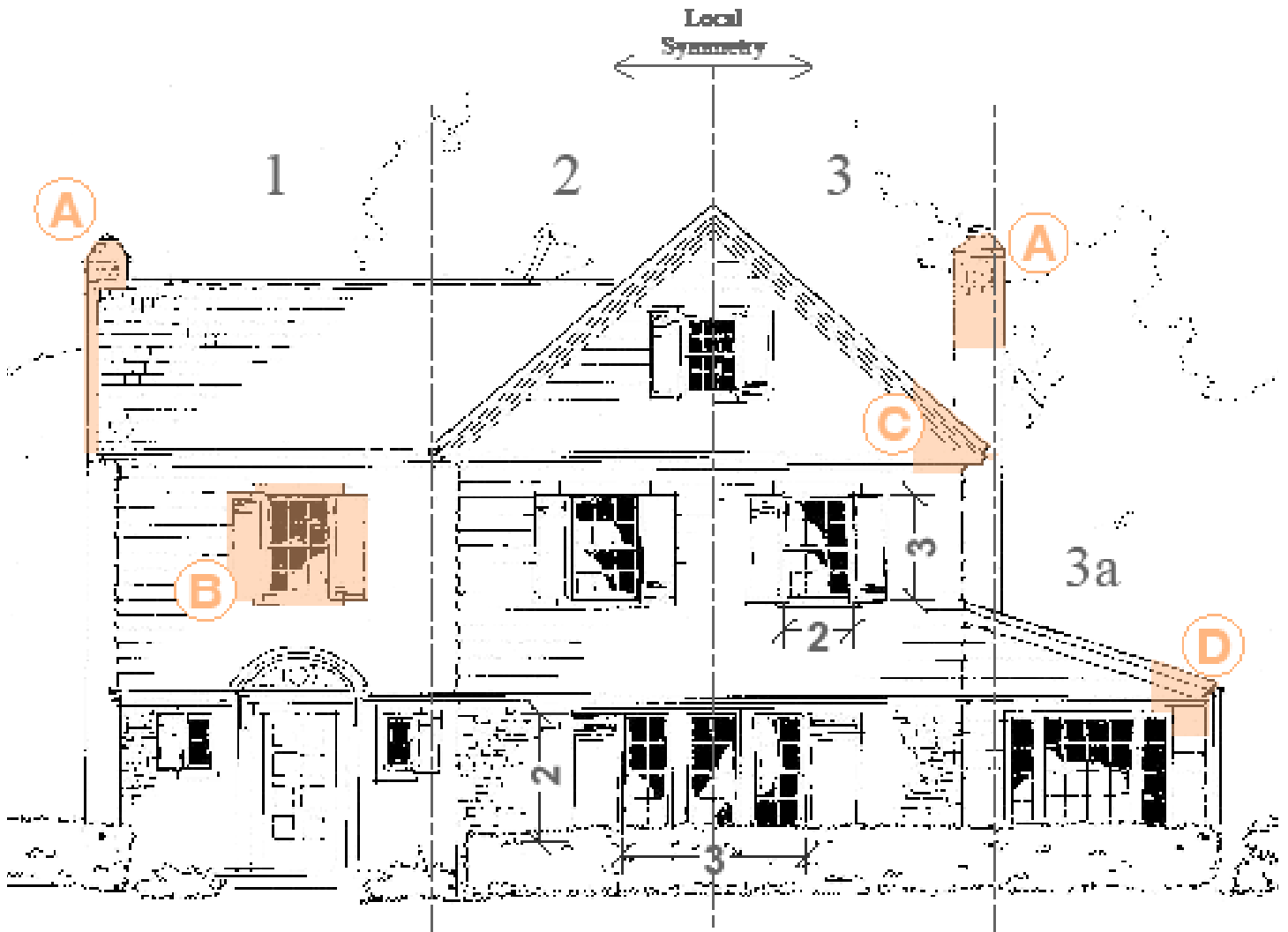

A. CHIMNEY: Provides a visual bookend for the composition. For more chimney examples, see pages 70-71.

B. WINDOW: 6-over-6 lite/muntin configuration. The proportion of the windows is 2:3. The shutters are properly sized for the windows. Each window has a simple casing and sill, both of which align with the clapboard siding.

C. EAVE: Pedimented gable.

D. EAVE: Simple rake eave.



# HOUSE DETAILS: HAMILTON'S GARDENS / SHERIDAN PARK DUPLEX

3-story duplex. Clapboard siding with vertical corner trim.



A. EAVE: Note eave is deeper in this example. Boxed-out eaves are not used. For more eave details, see pages 90-95.

B. WINDOW: Casings have back band and sloped sill. No “picture frame” casing is used. Note similar proportions of second-floor windows to those on the third floor (even though third floor windows are smaller). For more window details, see pages 104-109.

C. PORCH: Tuscan order with three round columns. Note porch is raised above grade. The floor apron/skirt projects so as not to align with column bases or entablature above. Porch roof relates to the main roof by half. For more porch details, see pages 96-103.

# HOUSE DETAILS: 3-BAY CAPE COD

2-story Cape Cod with clapboard siding and asphalt shingle roof. Note the smaller scale compared to houses of other neighborhoods. Vegetation lines the front of the house.



A. DORMER: Double-hung windows with 6-over-6 lite/muntin pattern. The windows maintain the same proportion, 2:3, as the windows below. The dormer roof pitch has a slope less than 12:12. For more dormer details, see pages 110-115.

B. EAVE:

C. CHIMNEY: For more chimney examples, see pages 70-71.

# HOUSE DETAILS: 3-BAY ASYMMETRICAL

2-story, 3-bay house with stone veneer, stucco, and slate roof. The windows and doors are horizontally and vertically aligned across the facade except at the main entry. Note vegetation along the front.



A. EAVE:

B. DORMER: Large wall dormer with a gable end and a peaked roof. For more dormer details, see pages 110-115.

C. DORMER: Wall dormer with a shed roof. The proportion of the individual windows is 1:2.5.

D. EAVE:

E. CHIMNEY: For more chimney examples, see pages 70-71.

# HOUSE DETAILS: MODERNIST HOUSE

2-story house with a Modernist aesthetic. Asymmetry between parts 1 and 2 balances windows on the second floor with doors on the first. Floor levels and window heights relate to neighboring houses (not shown).



A. CHIMNEY: Provides visual termination for left side of composition. For more chimney examples, see pages 70-71.

B. WINDOWS: Window proportions are related across the house. Even the garage door lites keep a proportion of 2:3.

# HOUSE DETAILS: 5-BAY

2-story, 5-bay house with brick veneer and a painted wood porch. This example has copper gutters, leader heads, and downspouts. Windows and doors are horizontally and vertically aligned across the composition. Note vegetation along the front.



A. CHIMNEYS: Provide visual bookends for the composition. For more chimney examples, see pages 70-71.

B. EAVE:

C. WINDOWS: 6-over-6 lite/muntin configuration. The proportion 2:3 is maintained even at the casement doors on the first floor. The top and bottom of the shutters align with the window opening. The shutter width is equal to half the window width.

D. PORCH: Attenuated columns. The first floor has a 3-bay division that relates to the 5-bay division of the second floor. Note that the width of the porch is one third of the width of the facade.

# HOUSE DETAILS: 5-BAY

2-story, 5-bay house with brick veneer and stone accents. Alignments of windows and doors are maintained horizontally and vertically across the composition. Note vegetation along the front.

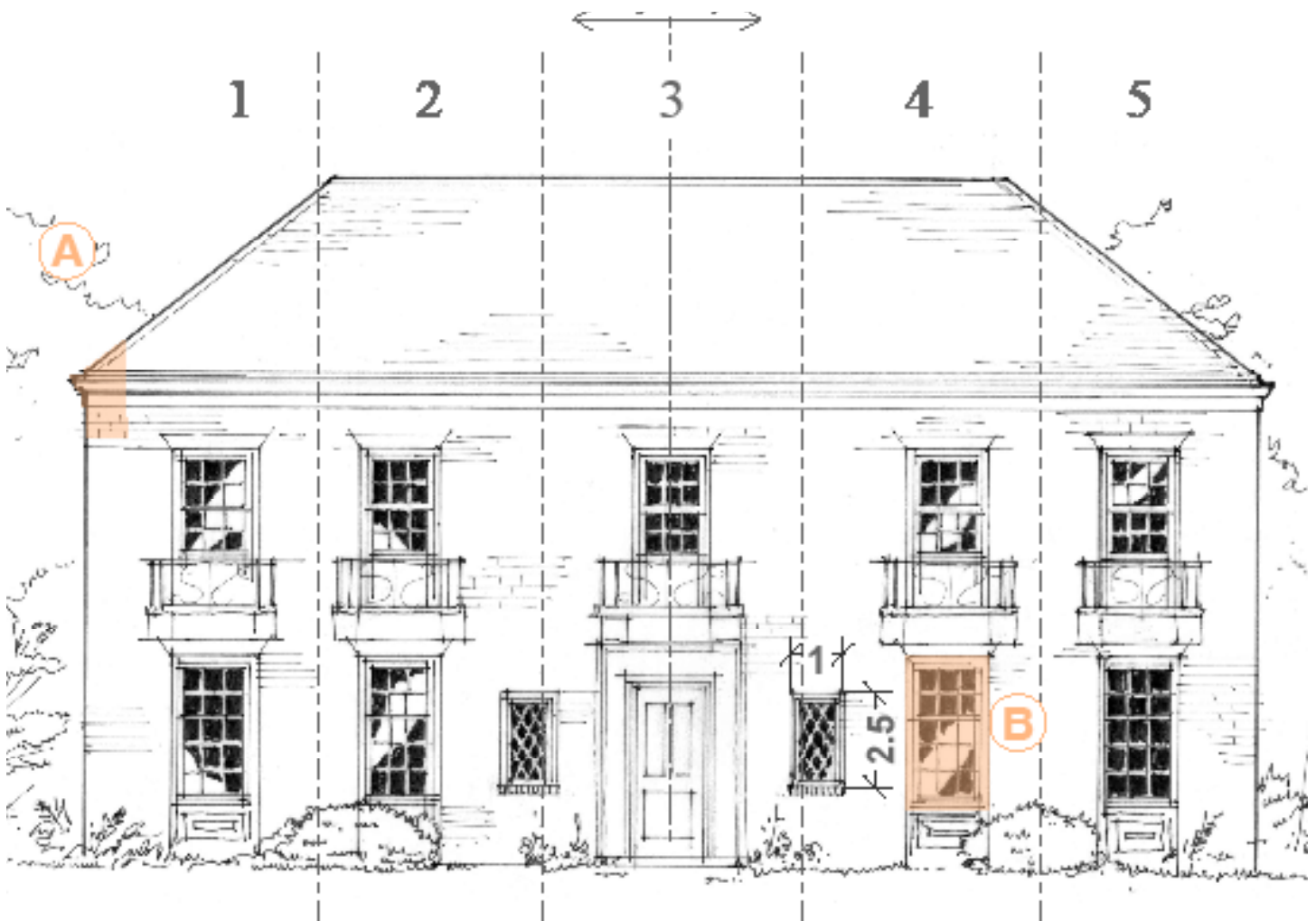

A. EAVE: For more eave details, see pages 70-71.

B. WINDOW: 6-over-9 cottage-type lite/muntin pattern. The proportion, 1:2.5, is maintained at other window openings and recesses. For more window details, see pages 104-109.

# HOUSE DETAILS: 5-BAY ASYMMETRICAL

2- or 3-story estate house with five divisions. The veneer is stone with limestone detailing. This example has copper gutters, leader heads, and downspouts. Windows and doors are horizontally aligned across the composition. Note vegetation along the front.

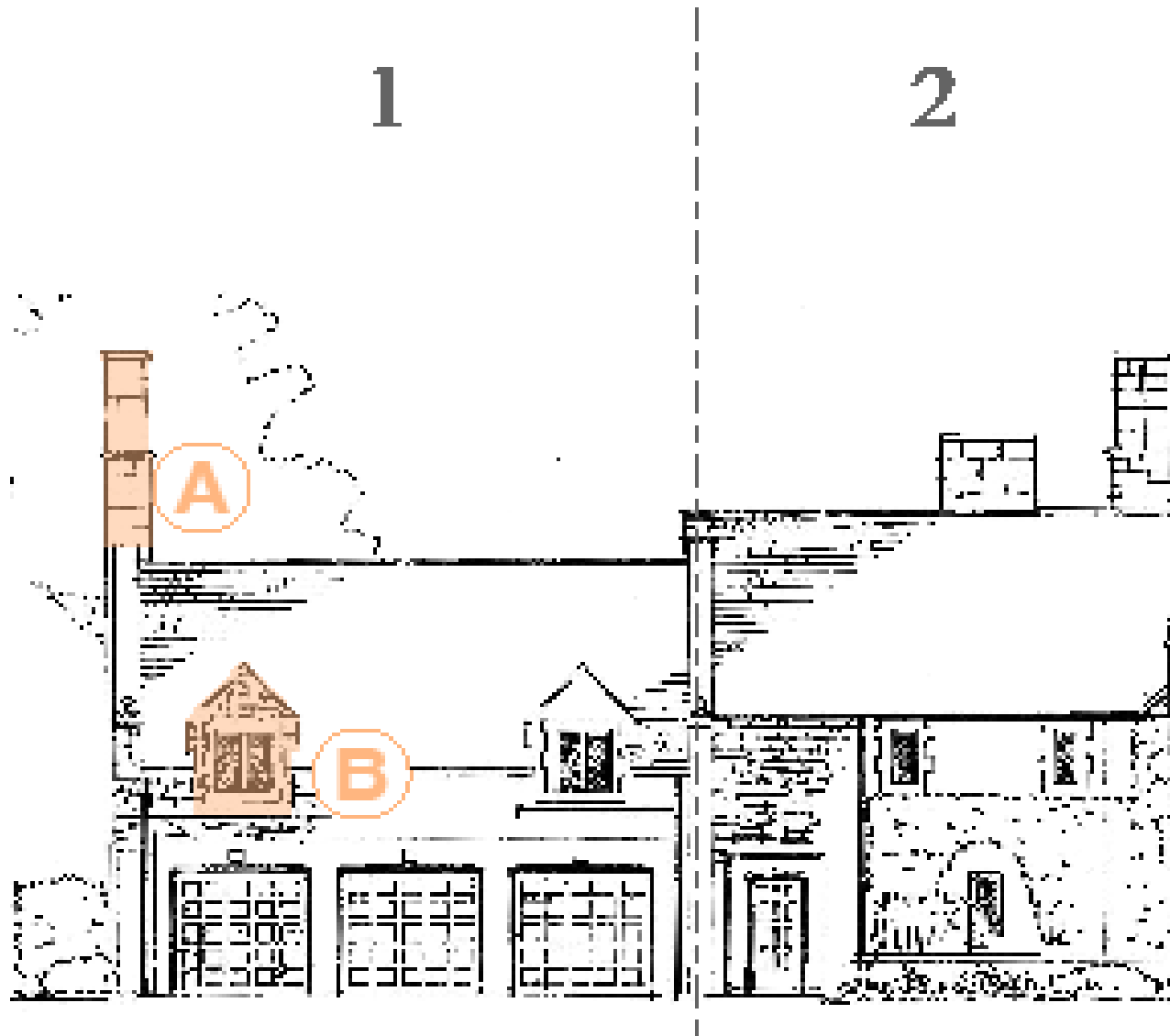

A. CHIMNEYS: Provide visual bookends for the composition. For more chimney examples, see p

B. DORMER: Stone wall dormer with slate roof. For more dormer details, see pages 110-115.

C. WINDOWS: The typical window on this house is a casement window with diamond lite patte  
across the house. This ratio creates a 2:3 proportion for paired windows.

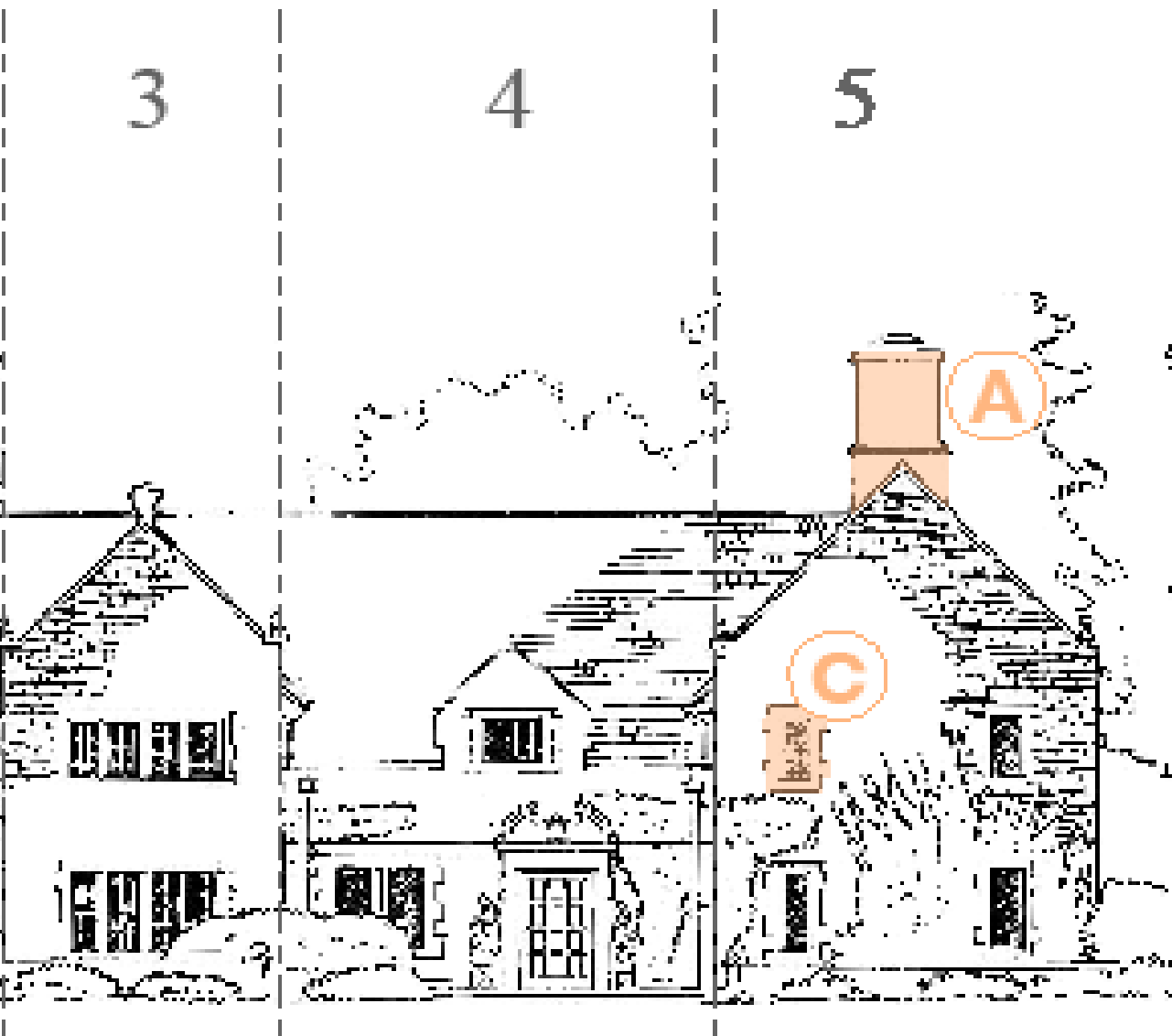

pages 70-71.

orn and limestone casing. The proportion of the windows, 1:2.5, is consistent



# MODERN DETAILS

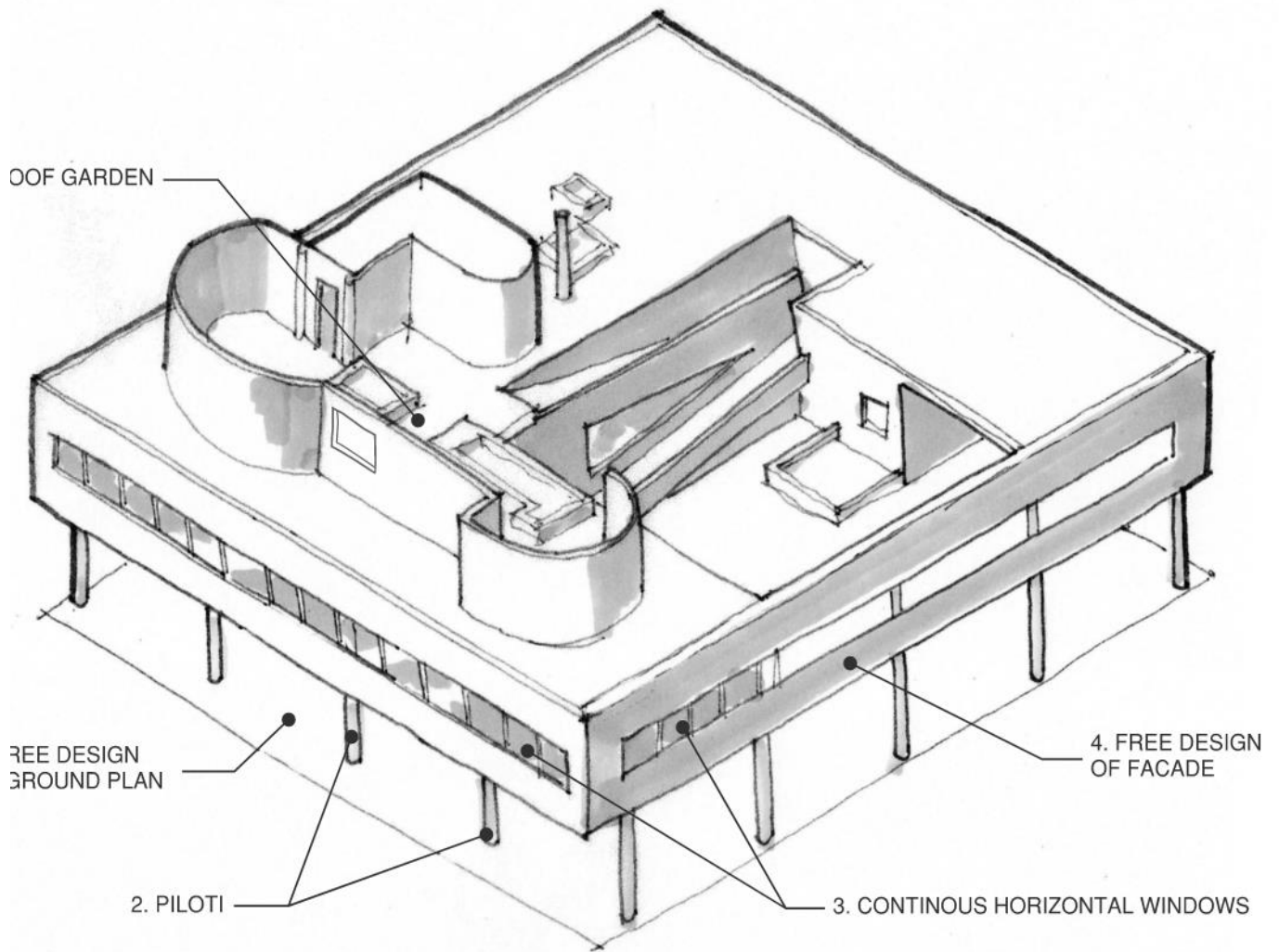

VILLA SAVOYE, FRANCE, 1931

ARB GUIDELINES SUPPLEMENTAL ILLUSTRATIONS  
MODERNIST PRECEDENCE: VILLA SAVOYE, FRANCE, 1931  
WM HEYER ARCHITECT 8-24-22

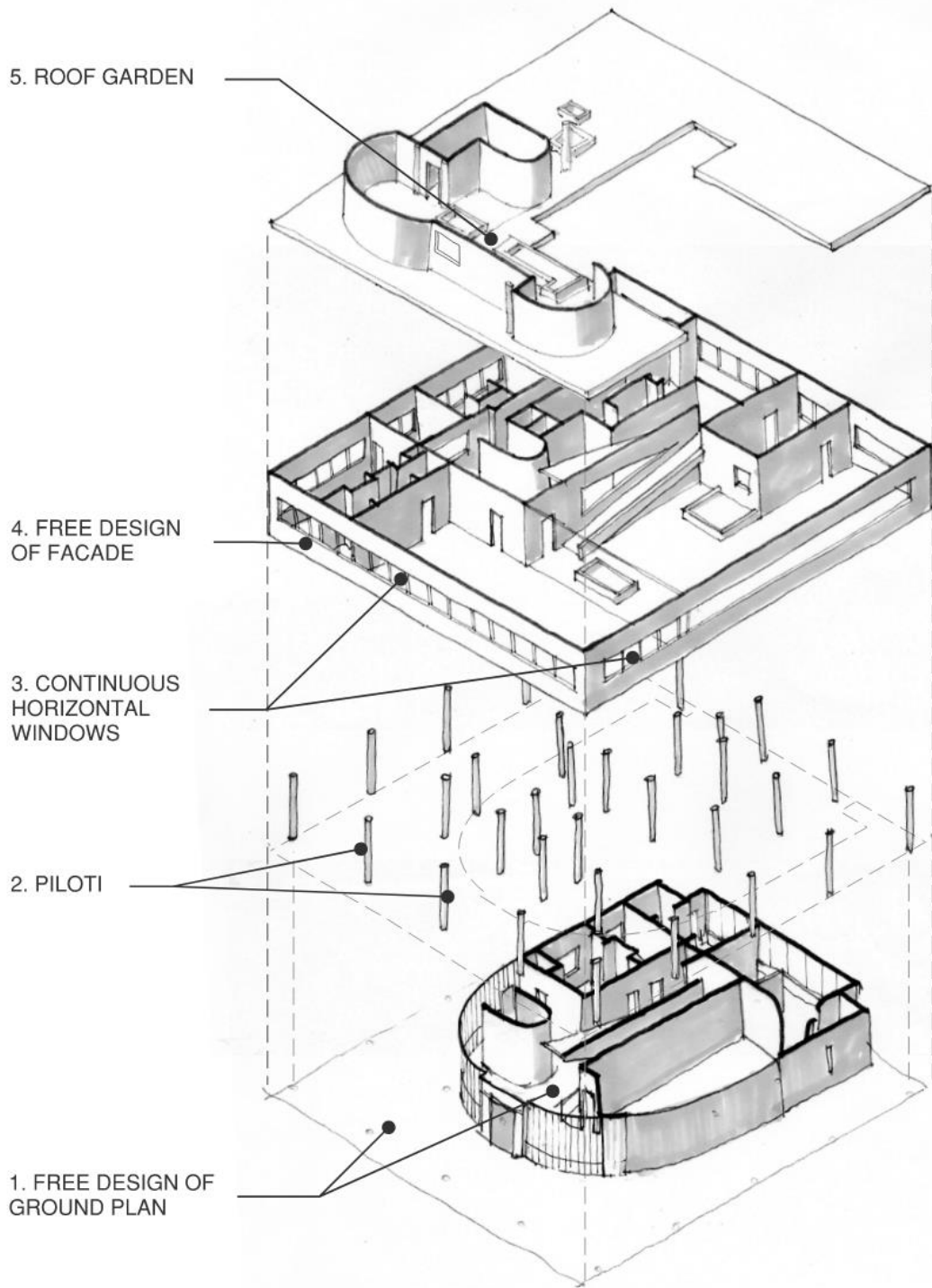

# MODERN DETAILS, CONT.

ARB GUIDELINES SUPPLEMENTAL ILLUSTRATIONS  
MODERNIST PORCH EXAMPLE  
WM HEYER ARCHITECT 8-24-22

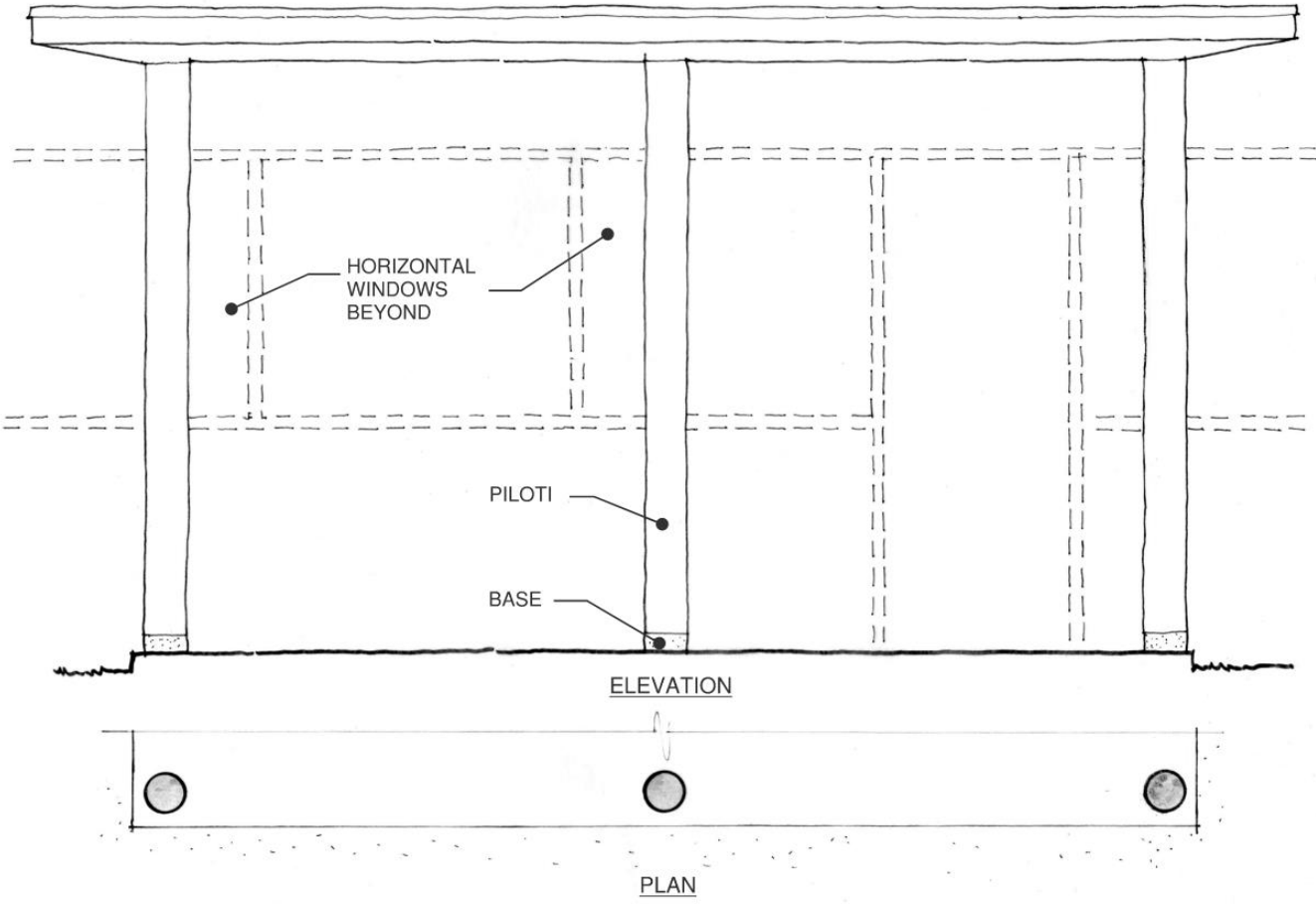

ARB GUIDELINES SUPPLEMENTAL ILLUSTRATIONS  
MODERNIST HOME EXAMPLE  
WM HEYER ARCHITECT 8-24-22

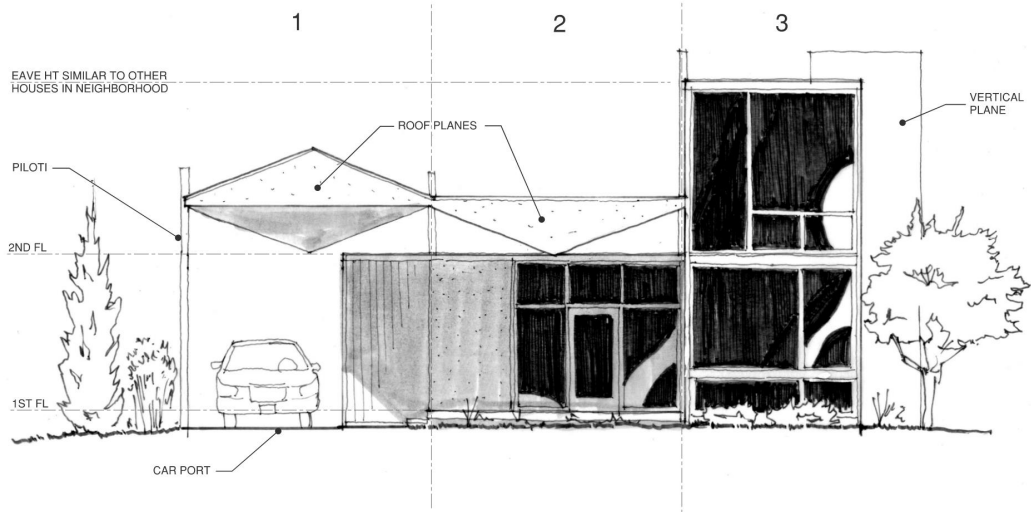

ARB GUIDELINES SUPPLEMENTAL ILLUSTRATIONS  
MODERNIST HOME EXAMPLE WITH ADDITIONS  
WM HEYER ARCHITECT 8-24-22

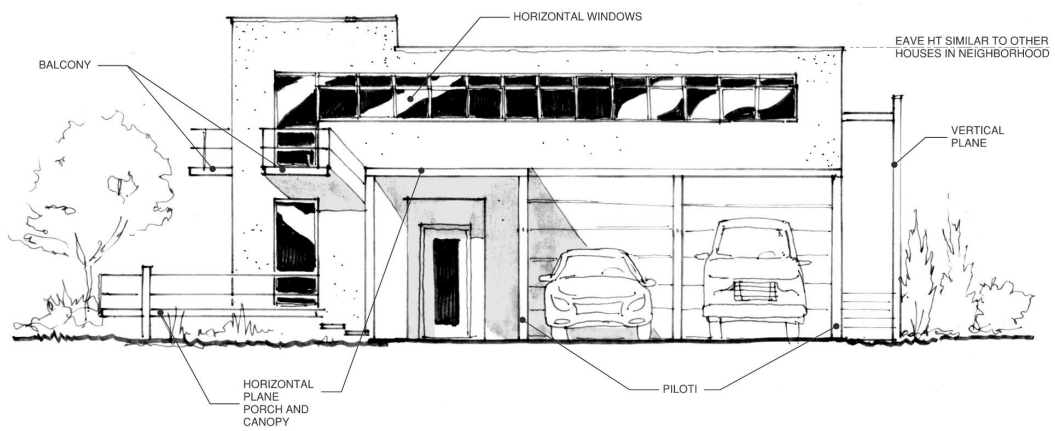

# PORCH AND COLUMN DETAILS

ARB GUIDELINES SUPPLEMENTAL ILLUSTRATIONS  
ALTERNATE PORCH AND COLUMN EXAMPLE  
WM HEYER ARCHITECT 8-24-22

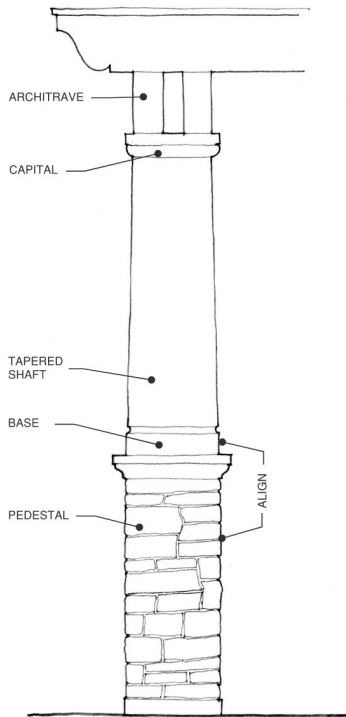

ARB GUIDELINES SUPPLEMENTAL ILLUSTRATIONS  
ALTERNATE PORCH AND COLUMN EXAMPLES  
WM HEYER ARCHITECT 8-24-22

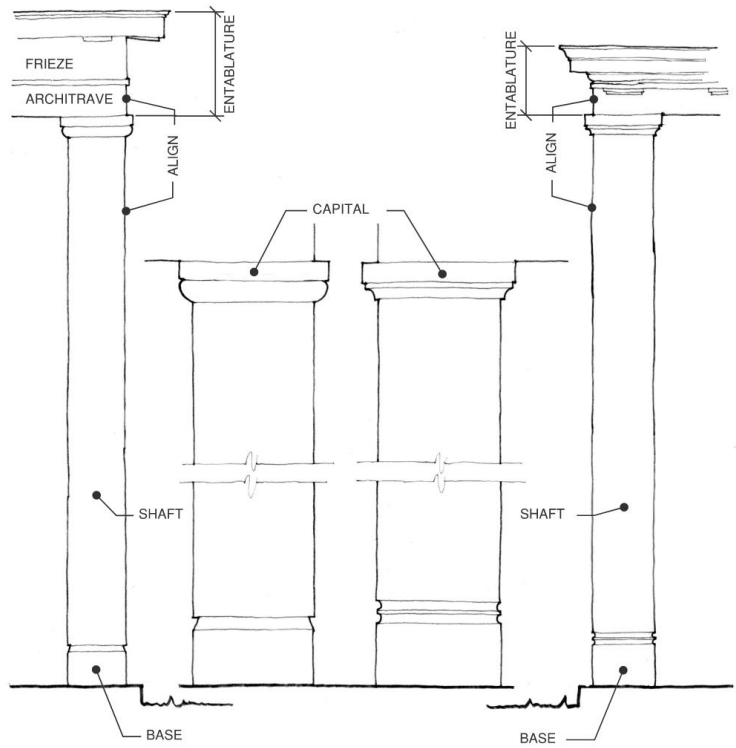

# ARTS AND CRAFTS DETAIL

ARB GUIDELINES SUPPLEMENTAL ILLUSTRATIONS  
ALTERNATE ARTS AND CRAFTS COLUMN/PIER EXAMPLE  
WM HEYER ARCHITECT 8-24-22

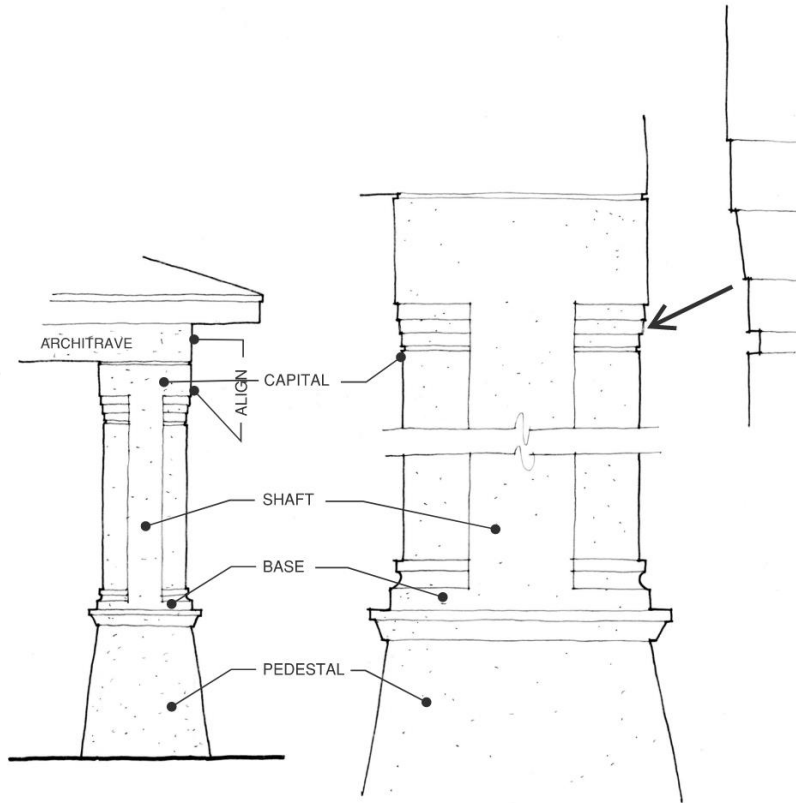

# PORCH AND COLUMN DETAILS

ARB GUIDELINES SUPPLEMENTAL ILLUSTRATIONS  
ALTERNATE PORCH AND BRICK PIER EXAMPLE  
WM HEYER ARCHITECT 8-24-22

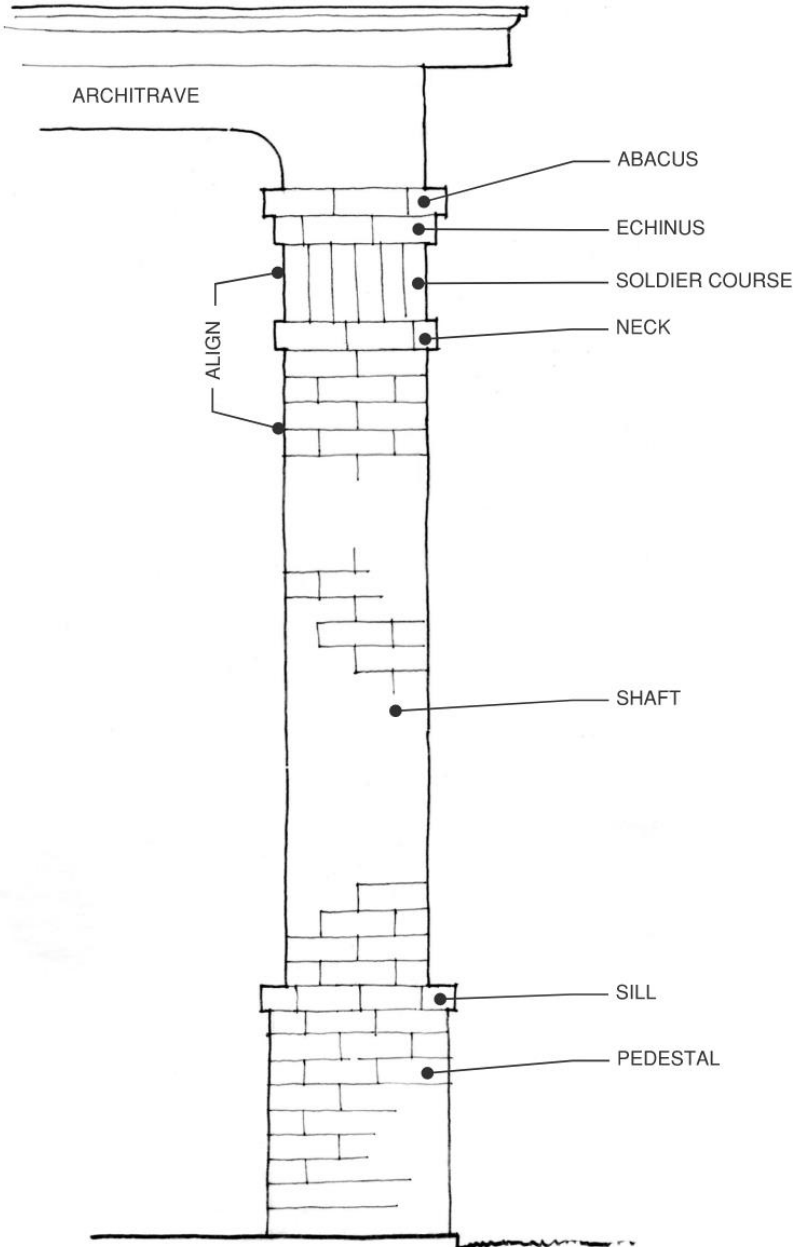

ARB GUIDELINES SUPPLEMENTAL ILLUSTRATIONS  
ALTERNATE ARTS AND CRAFTS PORCH AND COLUMN EXAMPLE  
WM HEYER ARCHITECT 8-24-22

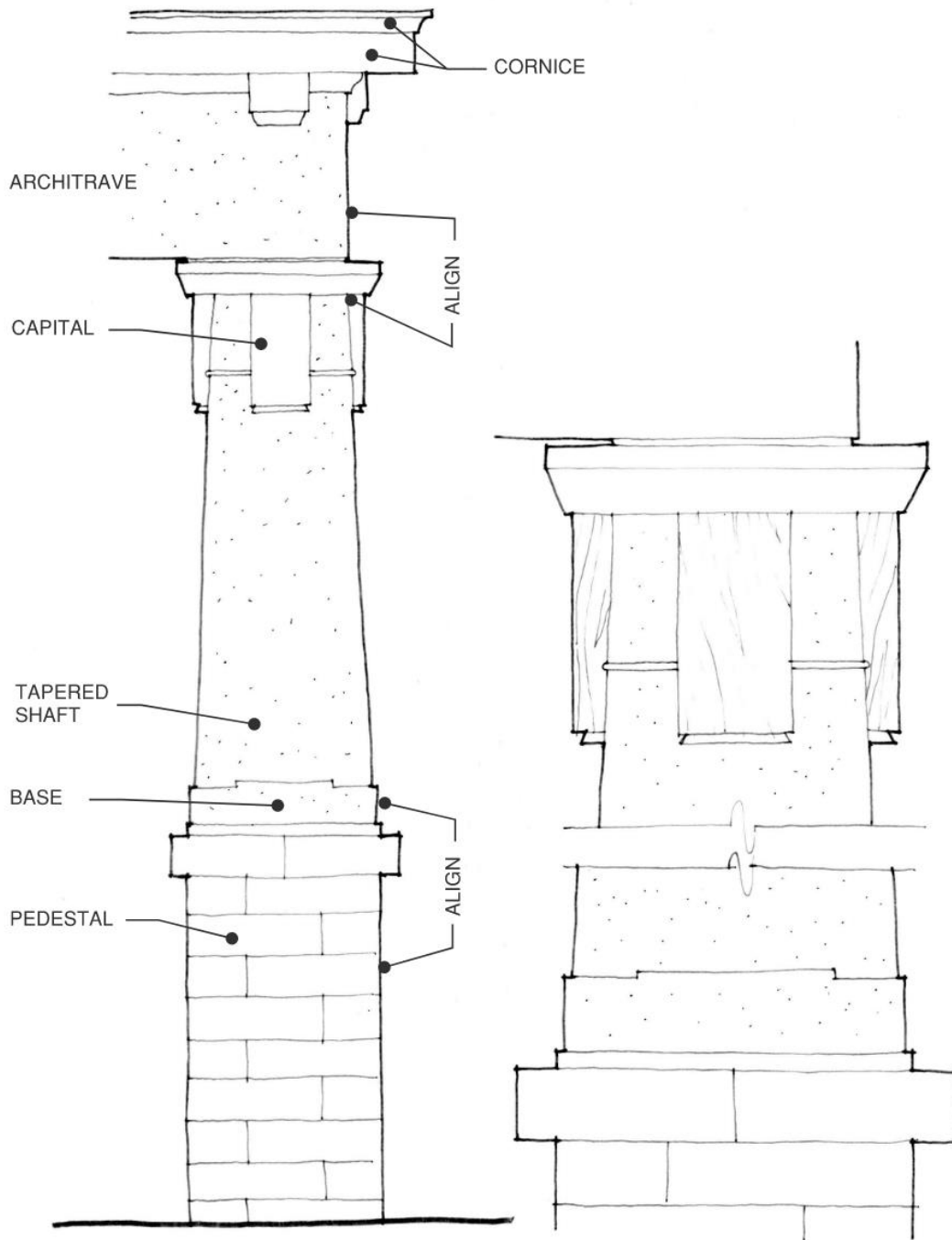



# SAMPLE DETAILS: CHIMNEYS





# SAMPLE DETAILS: ENTRIES





# SAMPLE DETAILS: ENTRIES





# SAMPLE DETAILS: SHUTTERS







# SAMPLE DETAILS: SLATE ROOF





# SAMPLE DETAILS: VENEER (BRICK)





# SAMPLE DETAILS: VENEER (COMBINATIONS)



# SAMPLE DETAILS: VENEER (SCHMEAR)



# SAMPLE DETAILS: VENEER (STONE)



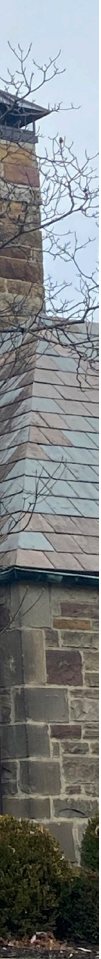



# SAMPLE DETAILS: VENEER (STUCCO)





# SAMPLE DETAILS: VENEER (WOOD SIDING)





# EAVE DETAILS

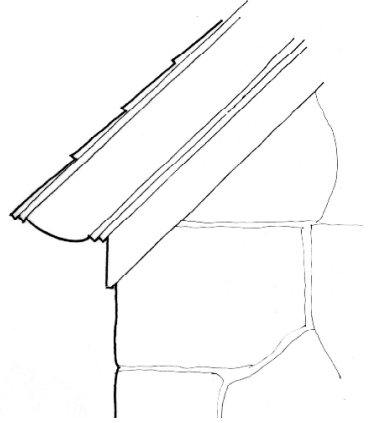
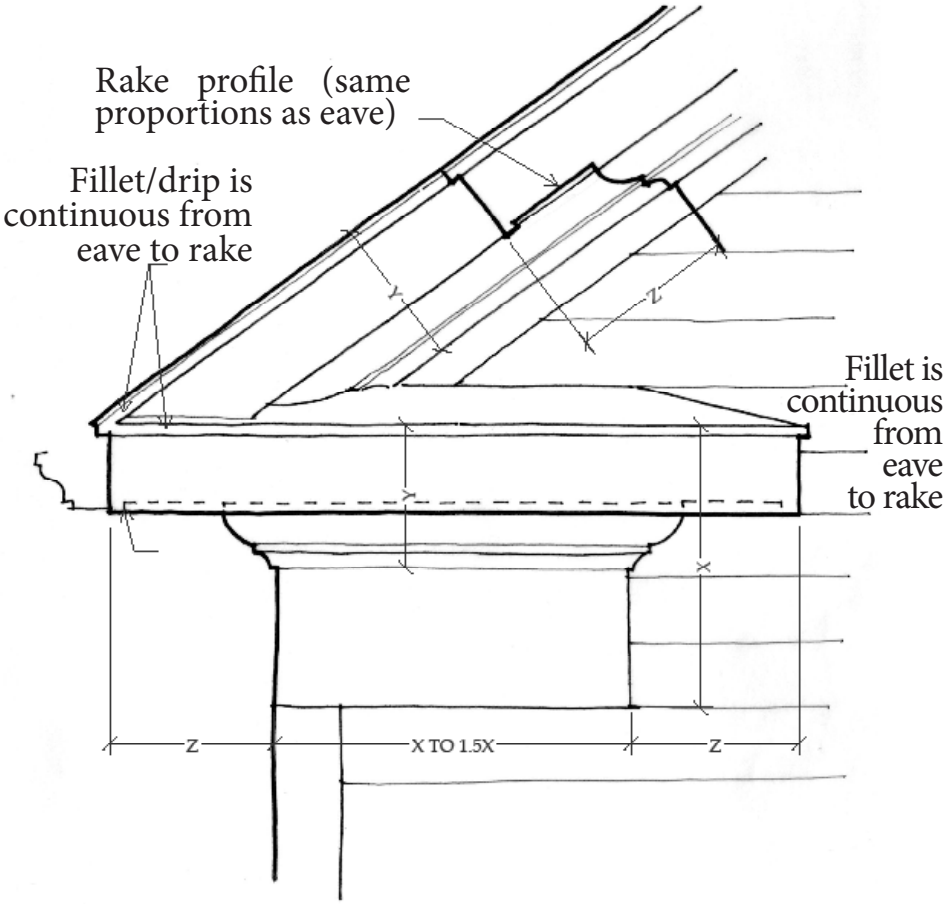

13

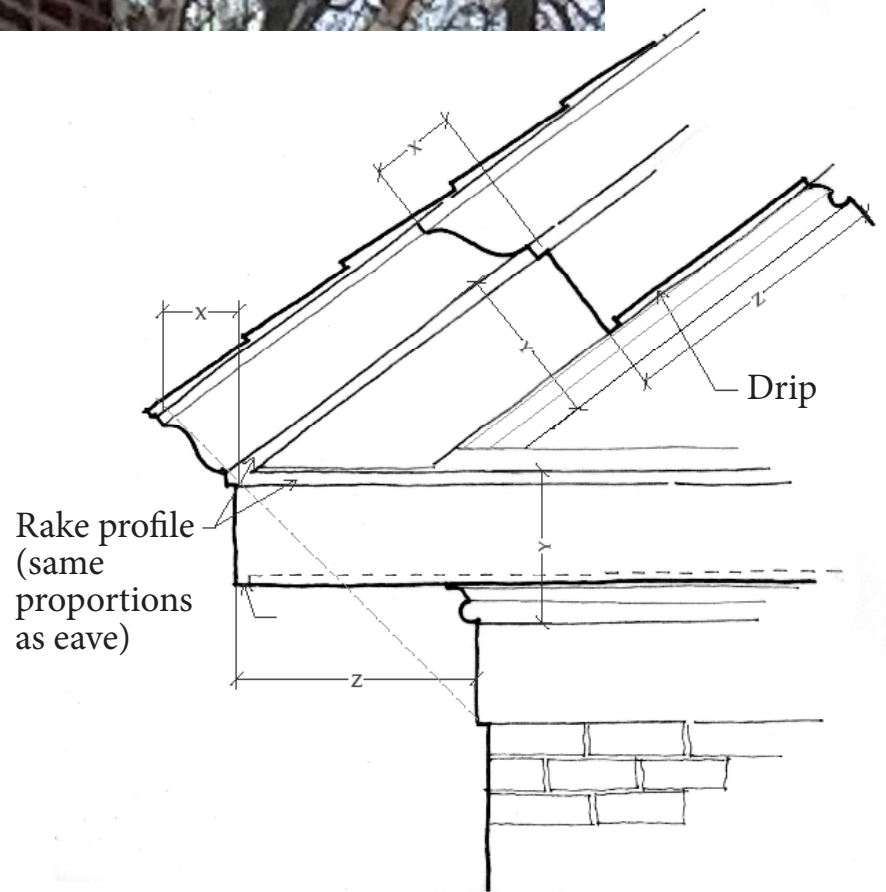

15

# EAVE DETAILS, CONT.

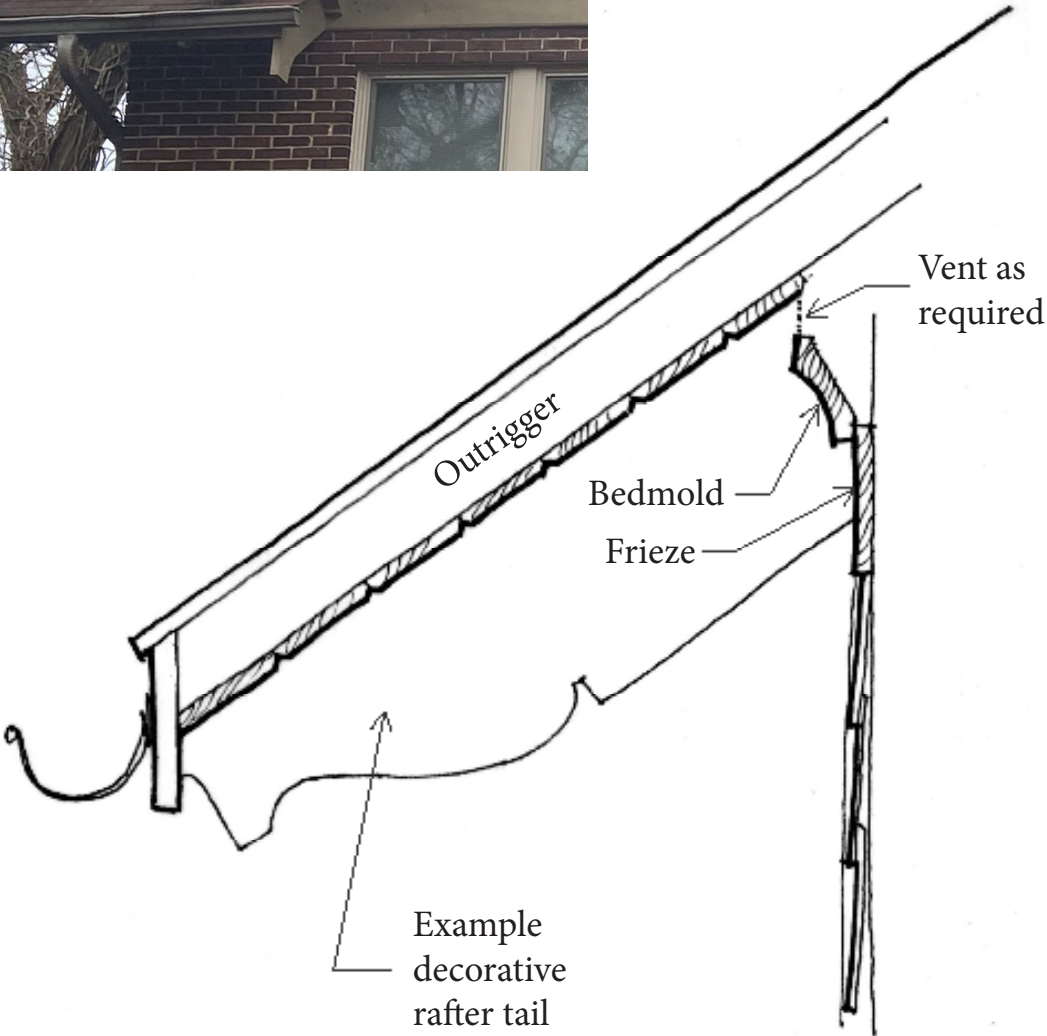

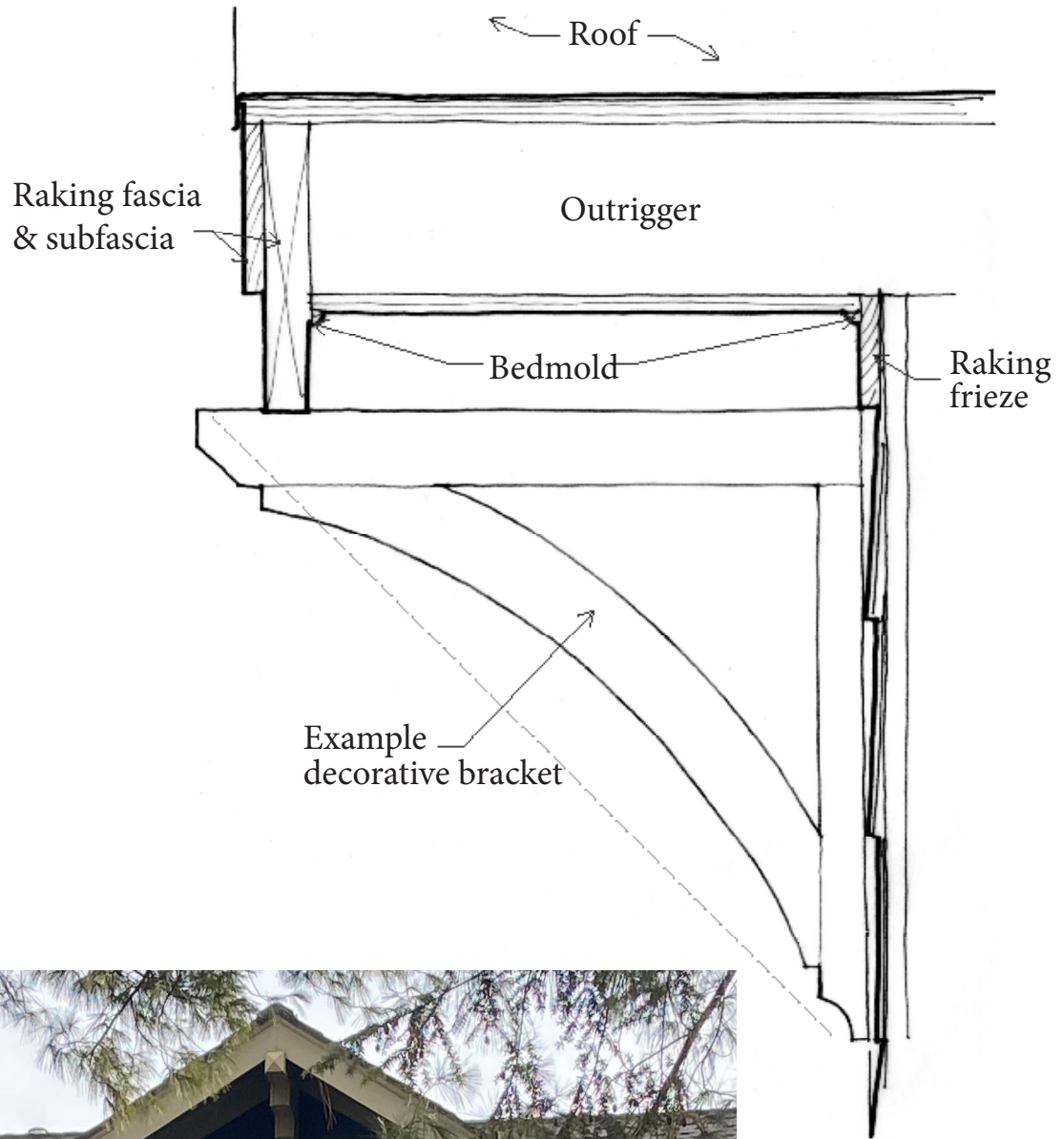



# EAVE DETAILS TO AVOID

Avoid fillets that are not continuous from eave to rake

Avoid eaves without hipped roof return

Avoid eaves without drip

Avoid boxed out eaves

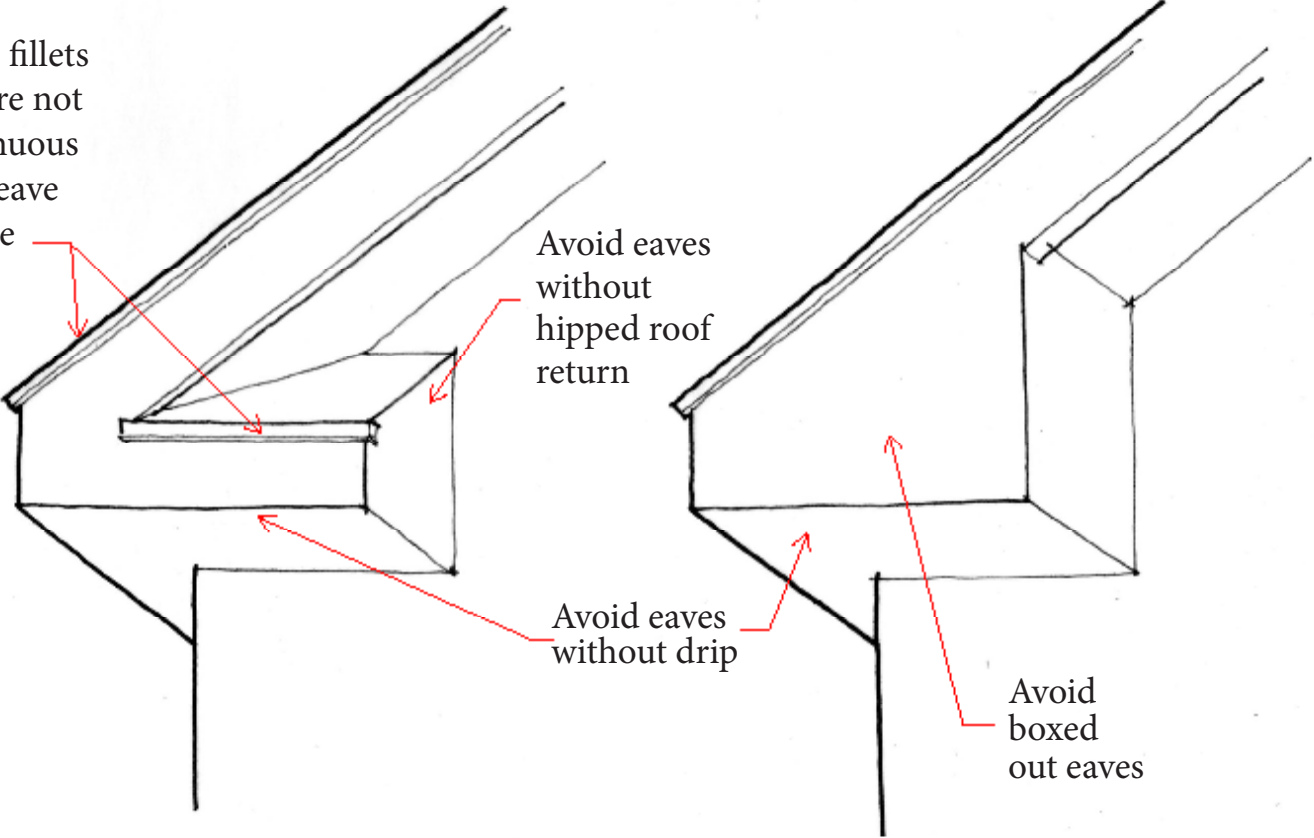

Avoid  
double  
crown

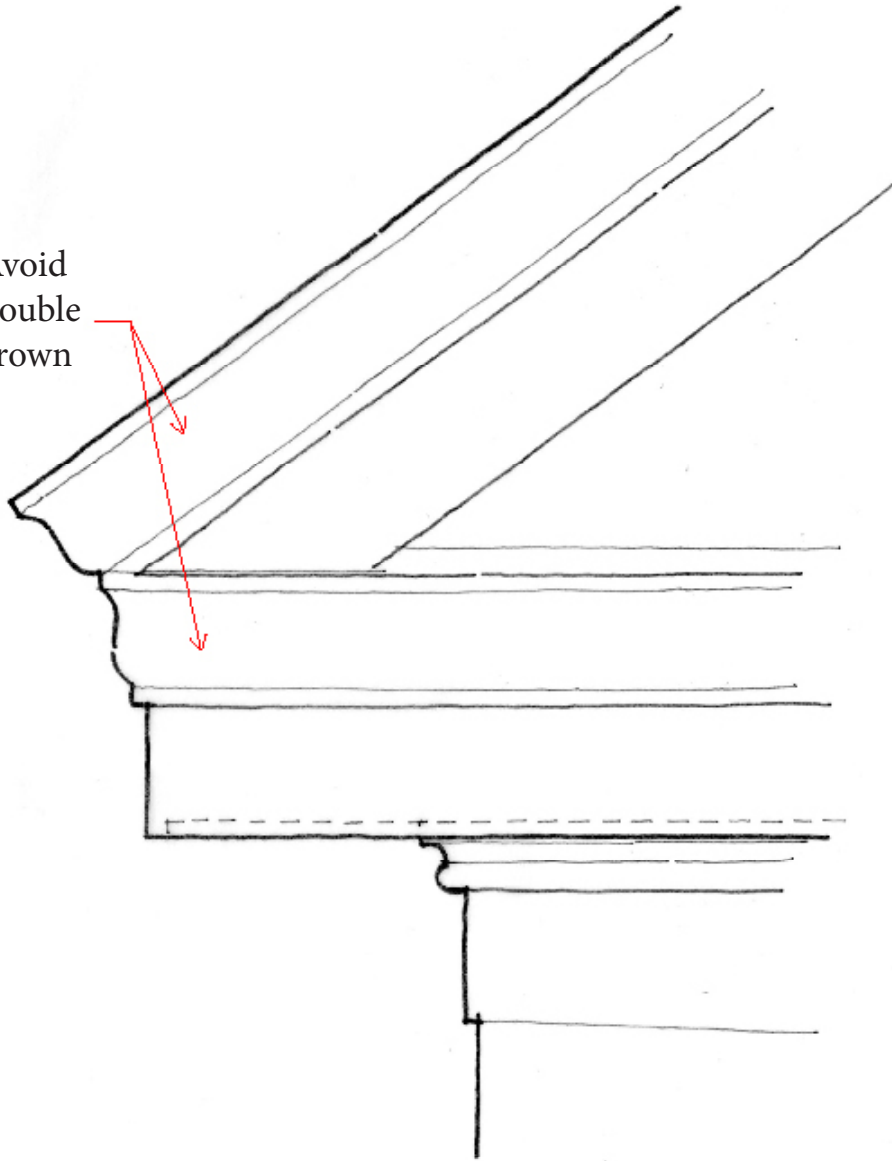

# SAMPLE DETAILS: PORCHES & COLUMNAR ORDERS





# PORCH DETAILS

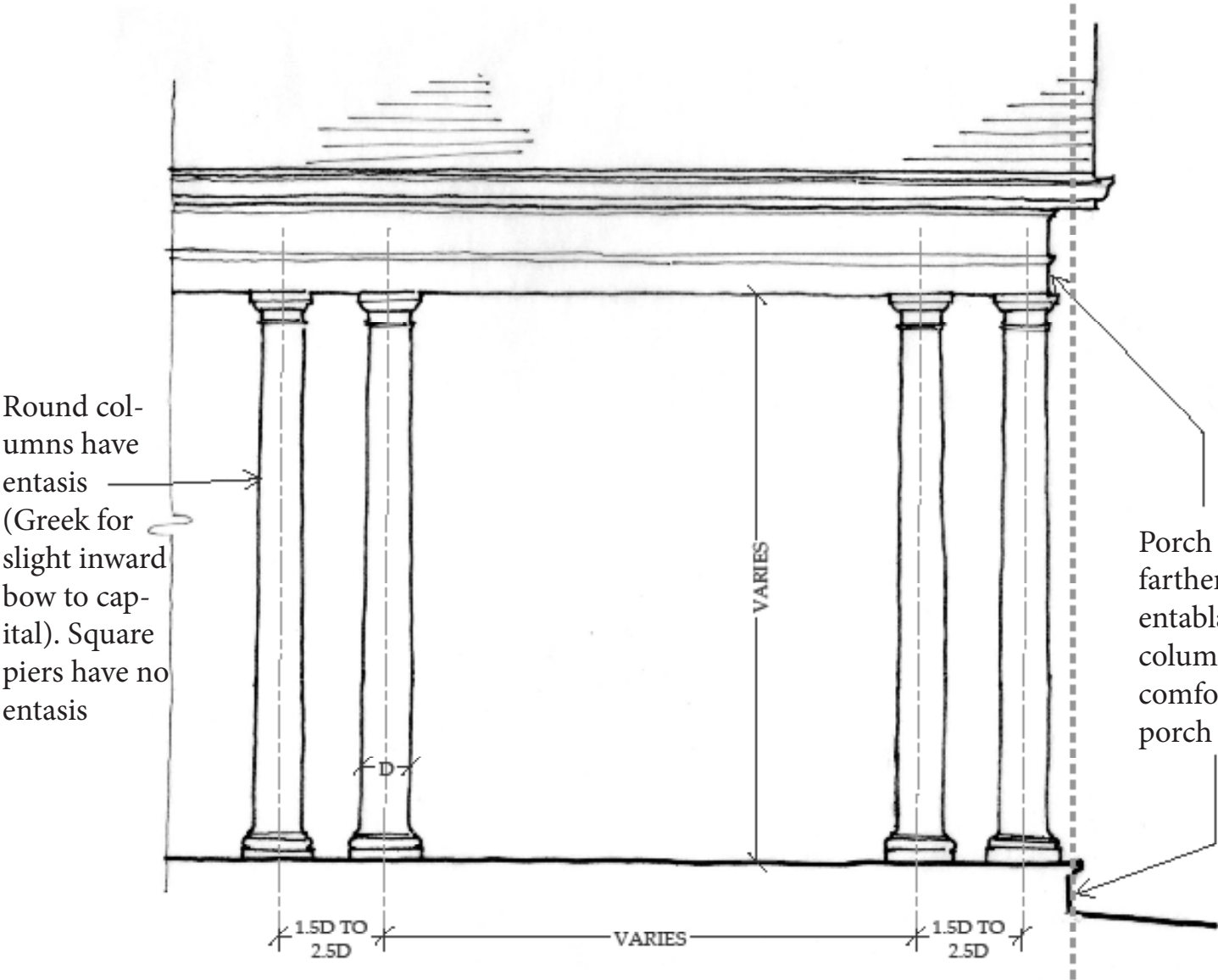

FRONT ELEVATION SHOWING PAIRED TUSCAN COLUMNS

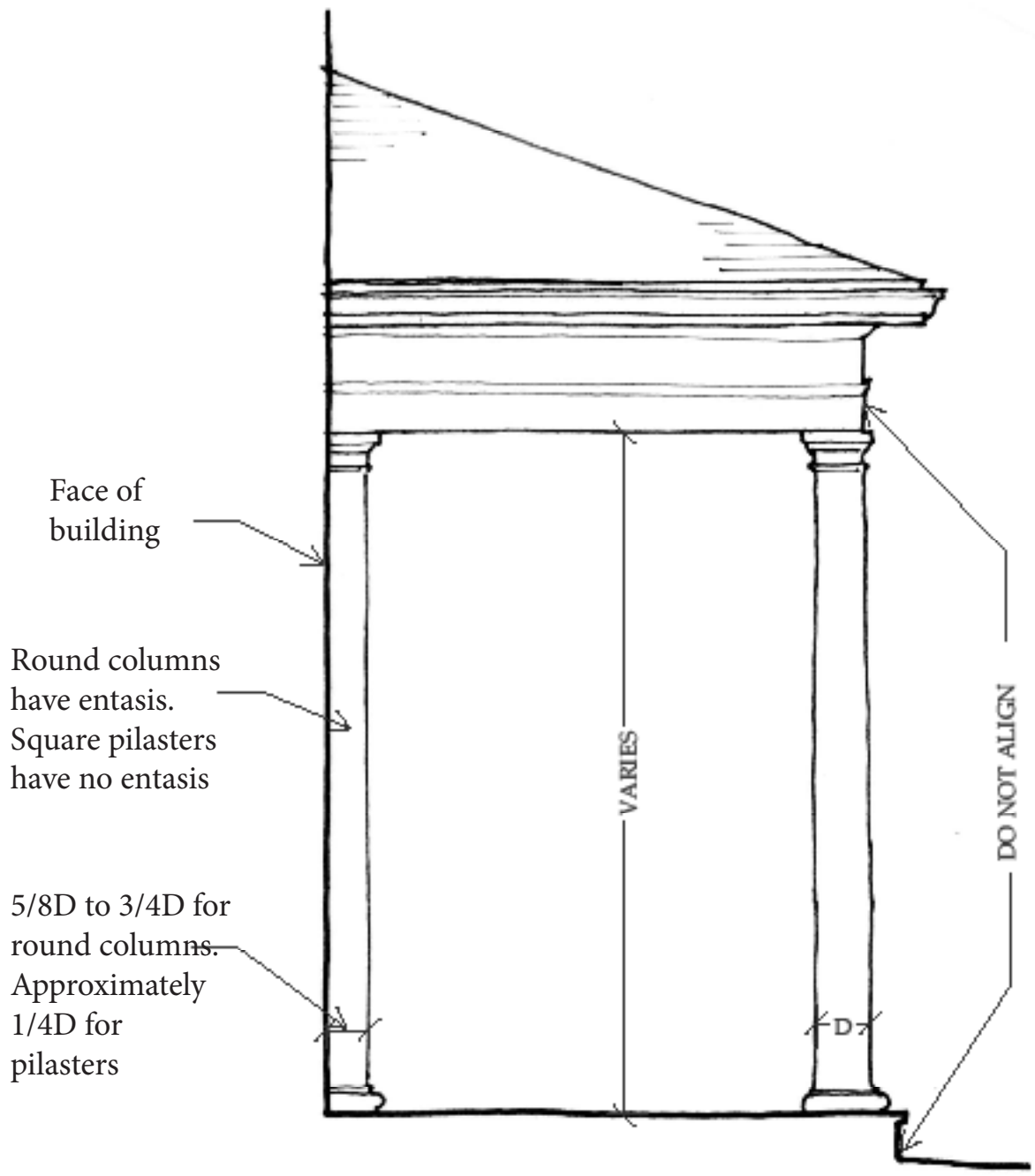

**SIDE ELEVATION SHOWING TUSCAN COLUMNS**

# PORCH DETAILS

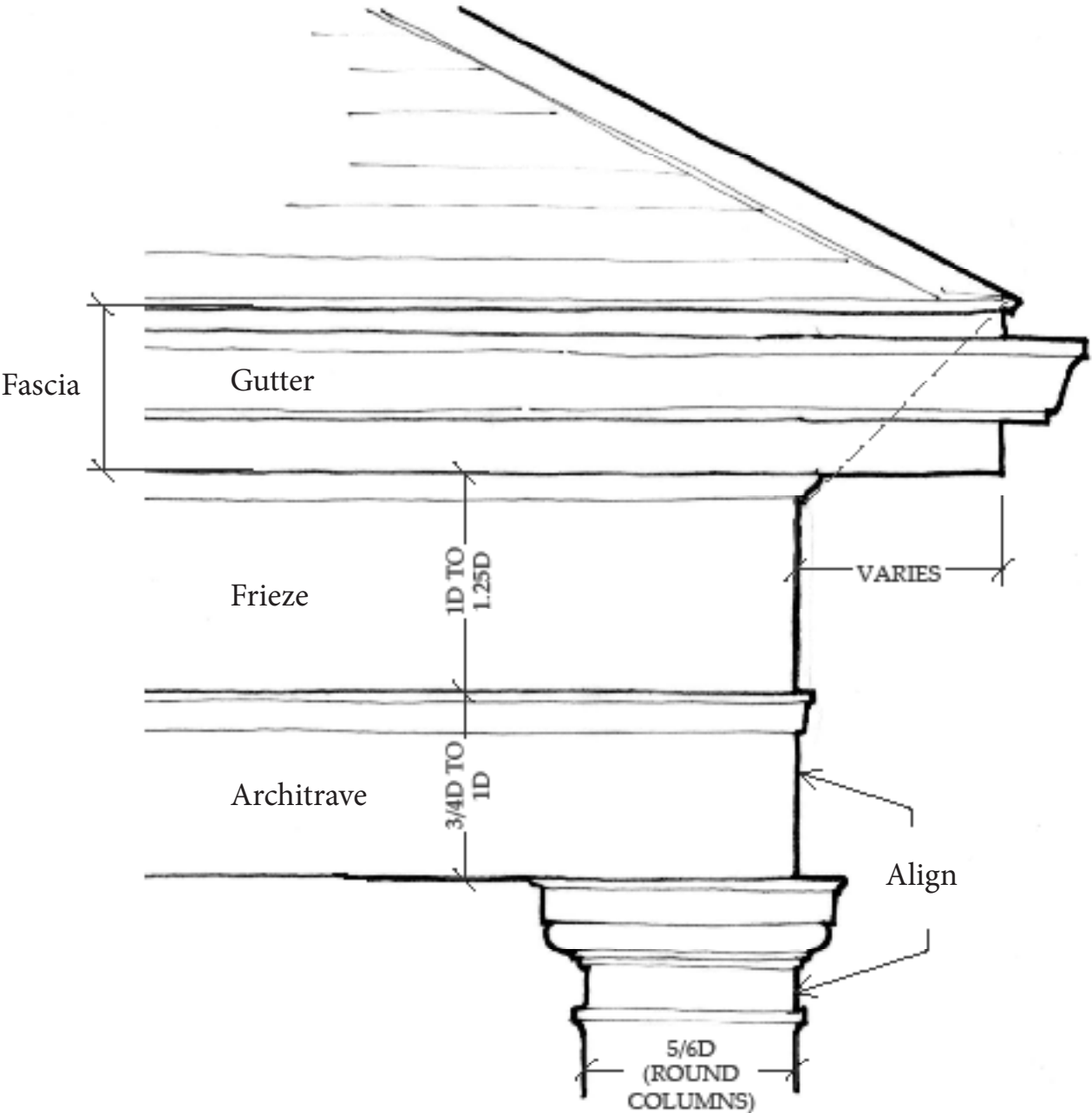

ENTABLATURE ELEVATION DETAIL

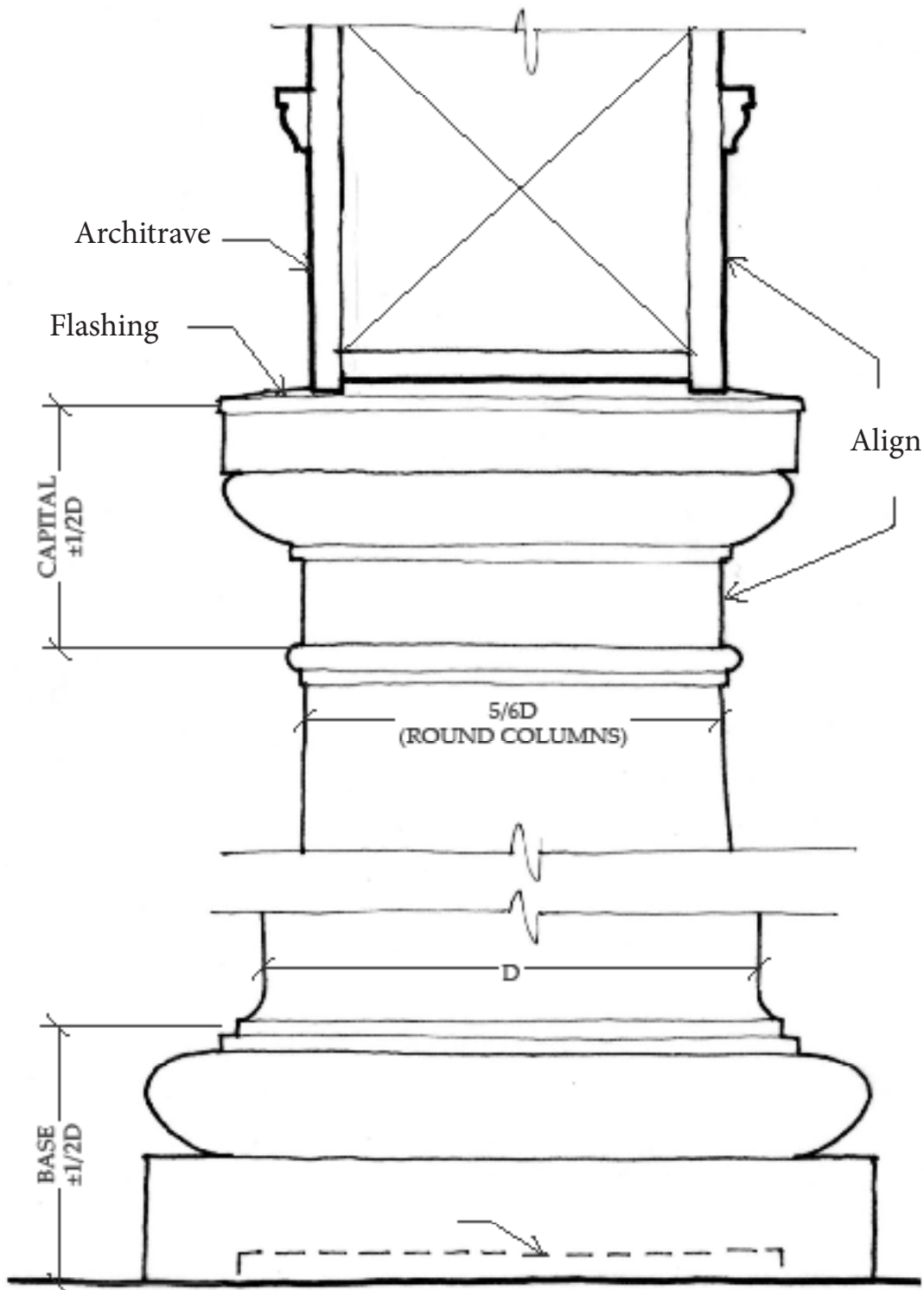

TUSCAN COLUMN DETAIL



# COLUMN DETAILS TO AVOID

## BEAM/LINTEL

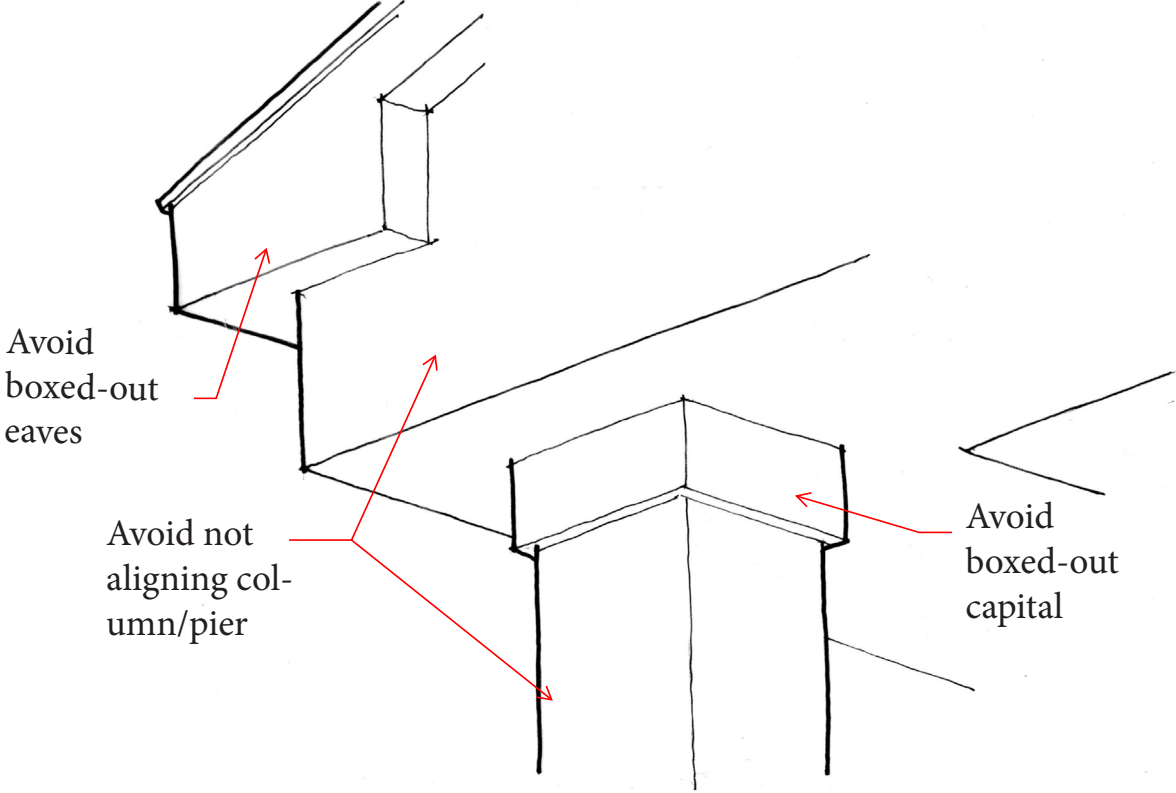
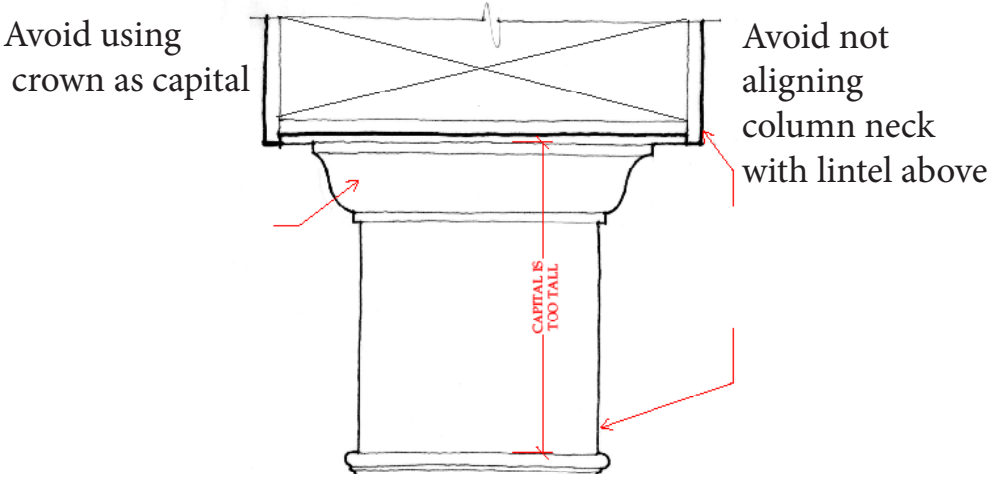

**AVOID BOXED-OUT CAPITALS AND BASES**

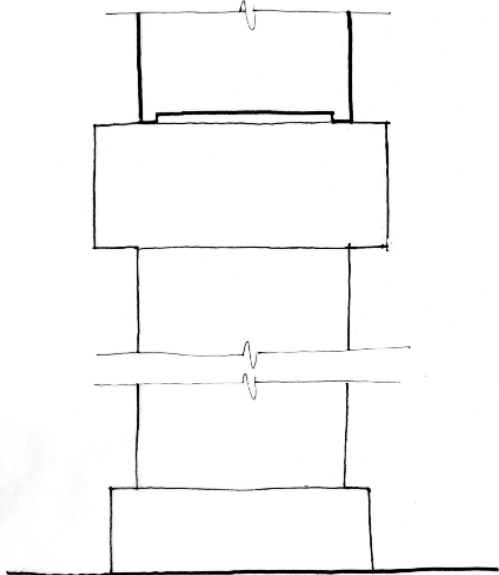
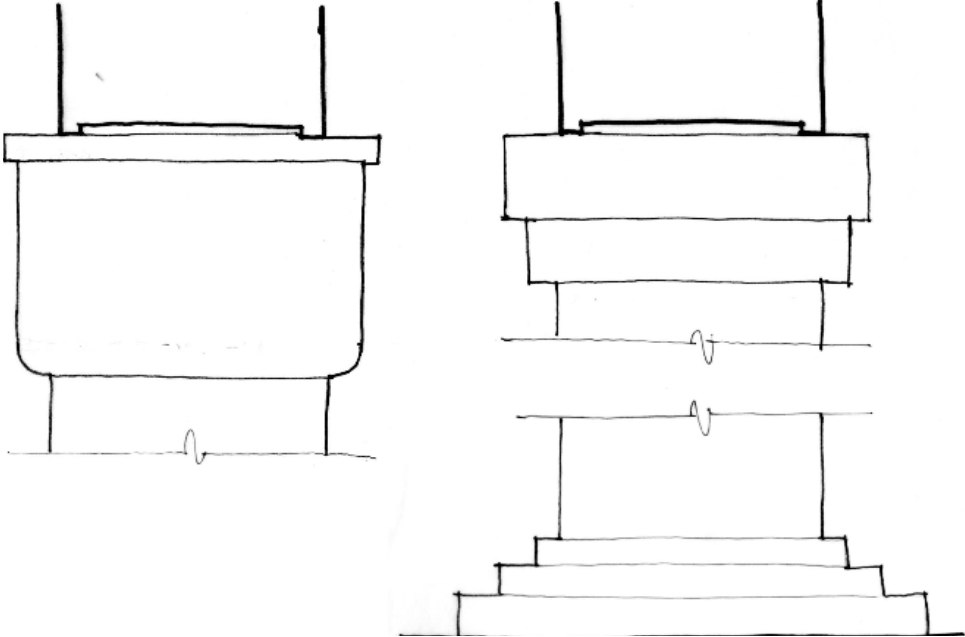

# SAMPLE WINDOW DETAILS





# WINDOW DETAILS

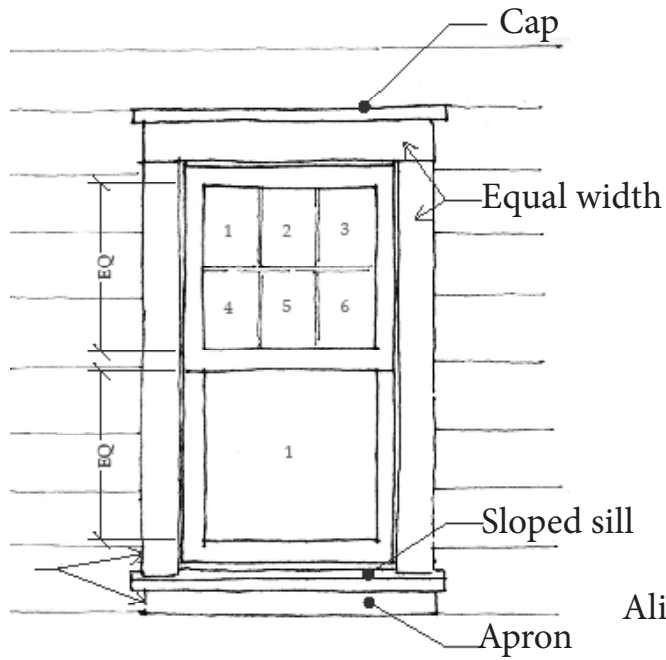

**6 OVER 1**

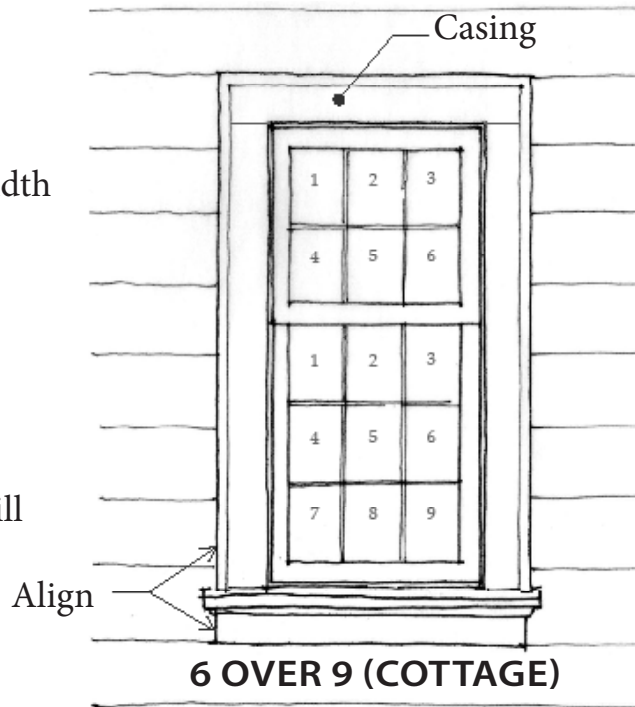

**6 OVER 9 (COTTAGE)**

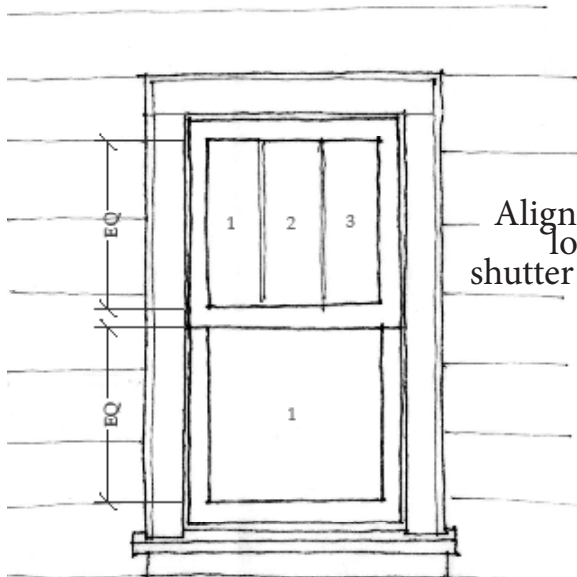

**3 OVER 1 (COMMON TO ARTS & CRAFTS AND BUNGALOWS)**

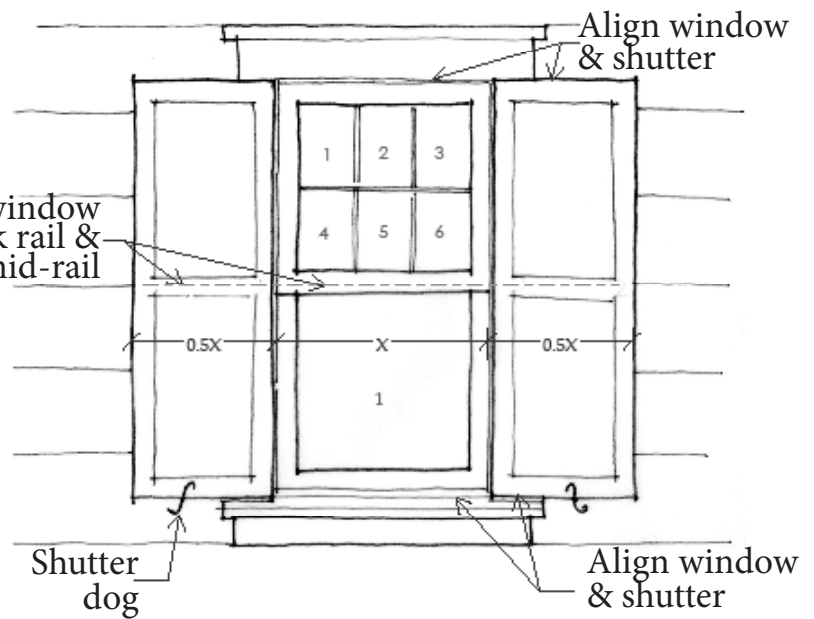

**6 OVER 1 WITH SHUTTERS**

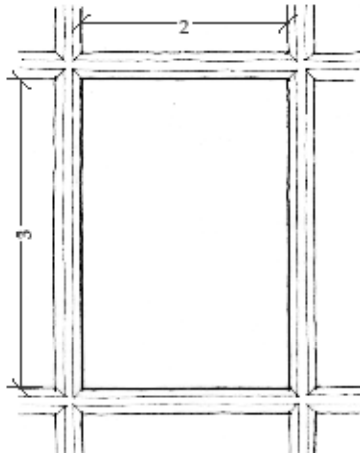

## TYPICAL WINDOW GLASS LITE PROPORTIONS

Though the illustration to the left is a “typical” glass lite proportion, many windows have other lite (grid) shapes and sizes. What is important in replacements, repairs, additions, etc... is that the new windows maintain the same proportions as the original design and maintain continuity and integrity of design.

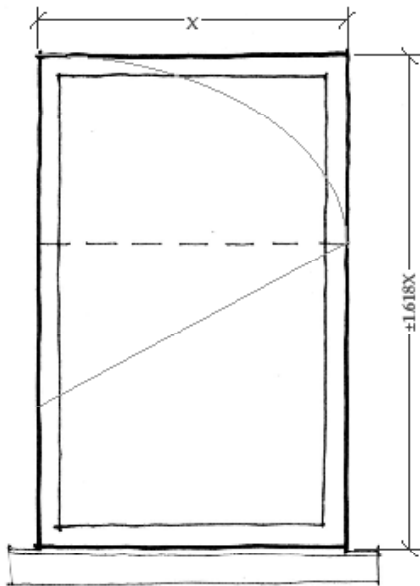

**MID-CENTURY MODERN  
SINGLE WINDOW USING  
GOLDEN RATIO**

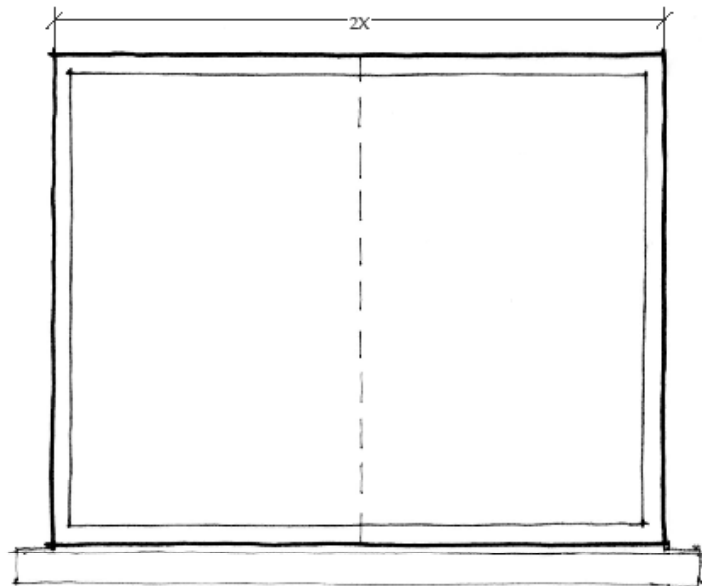

**“DOUBLE-SIZE” WINDOW  
USING GOLDEN RATIO**

# WINDOW DETAILS

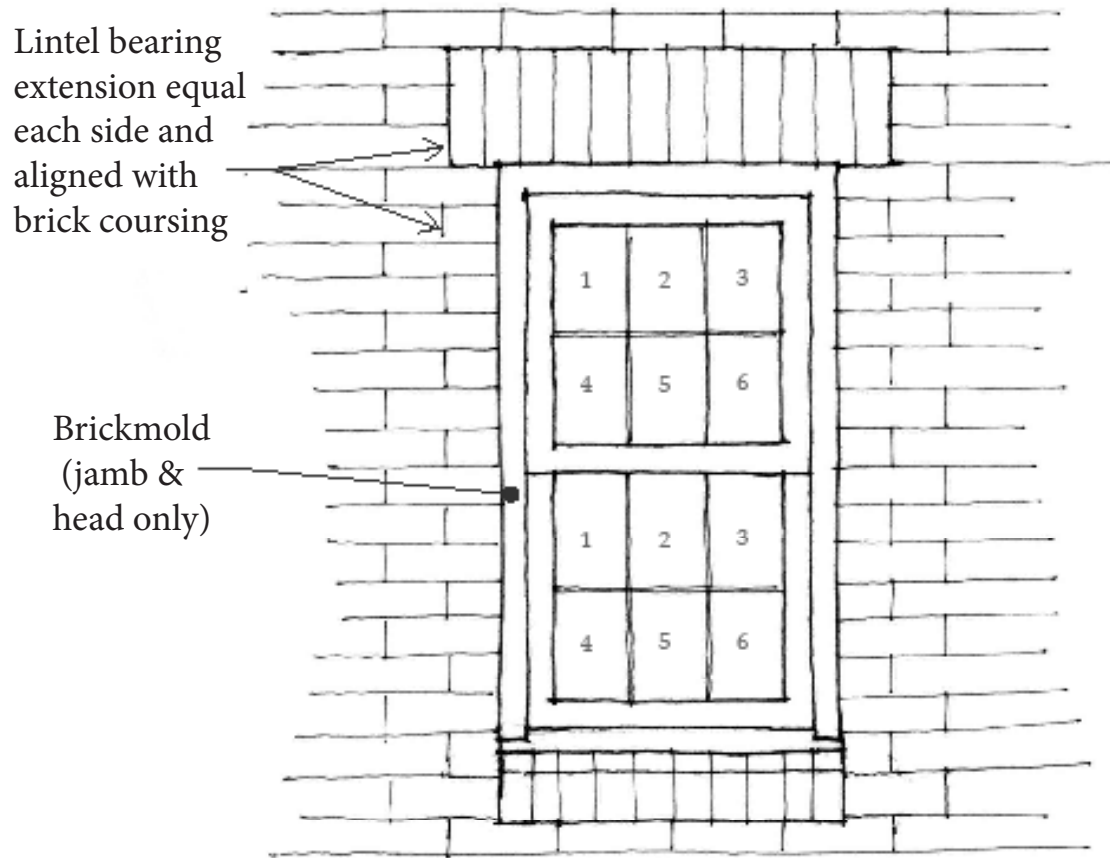

**WINDOW IN BRICK VENEER WITH BRICK LINTEL AND BRICK SILL**

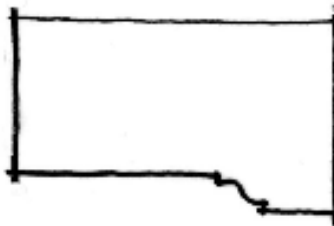

**EXAMPLE BRICKMOLD PROFILE**

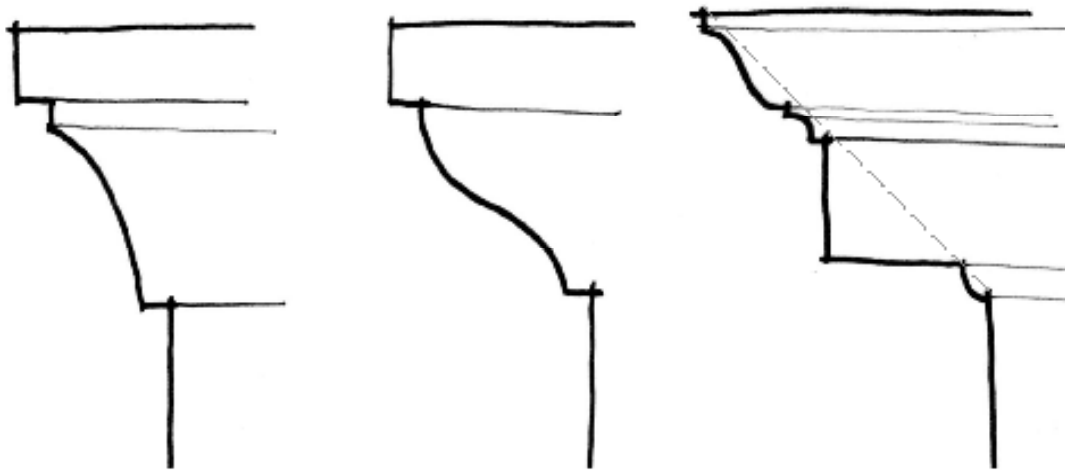

**WINDOW CASING CROWN EXAMPLES**

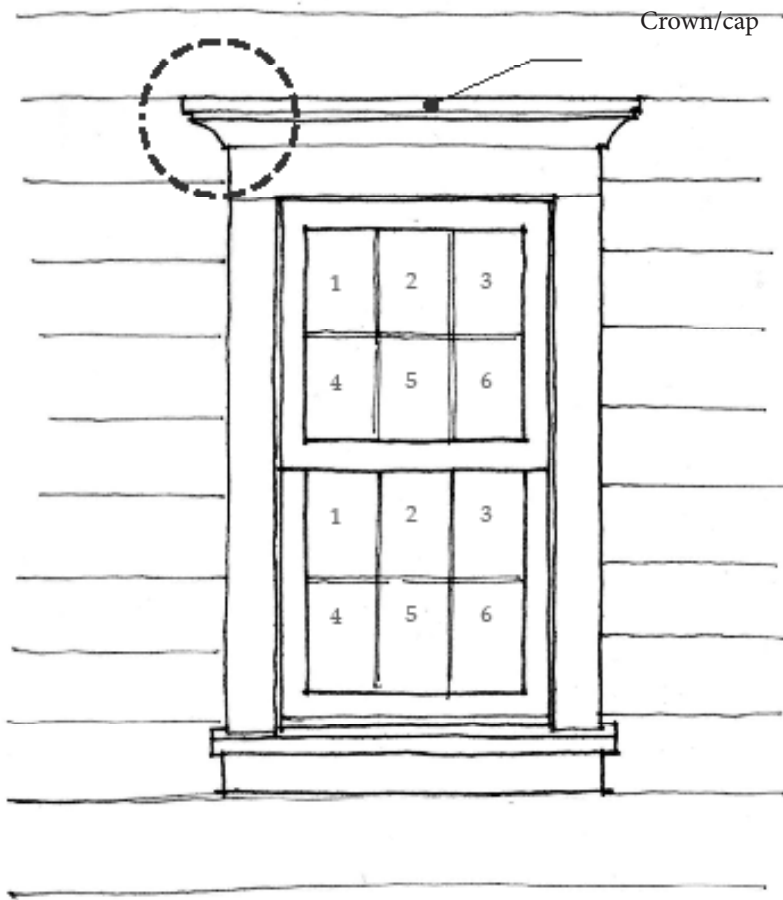

**6 OVER 6**



# SAMPLE DETAILS: DORMERS





# DORMER DETAILS

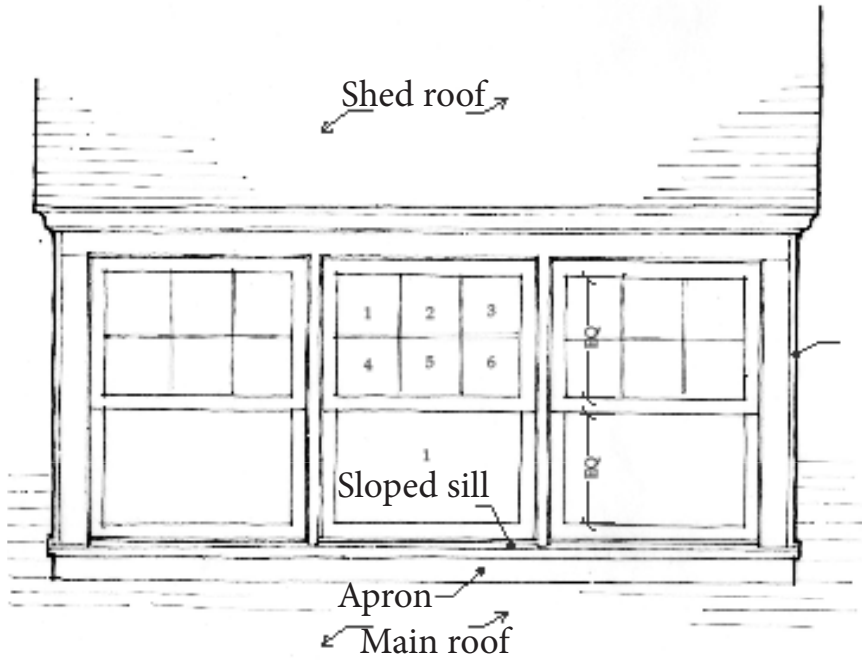

**FRONT ELEVATION**

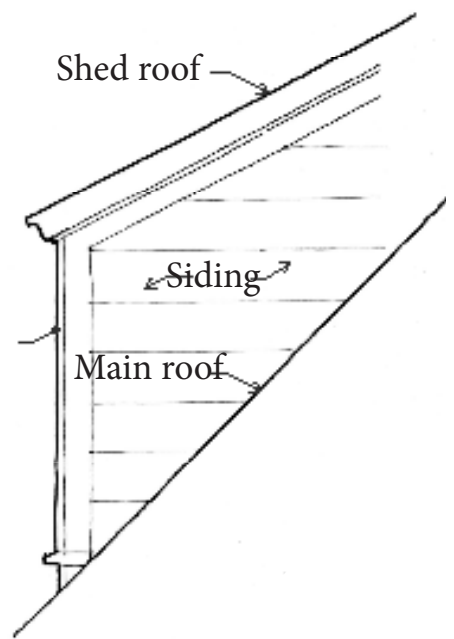

**SIDE ELEVATION**

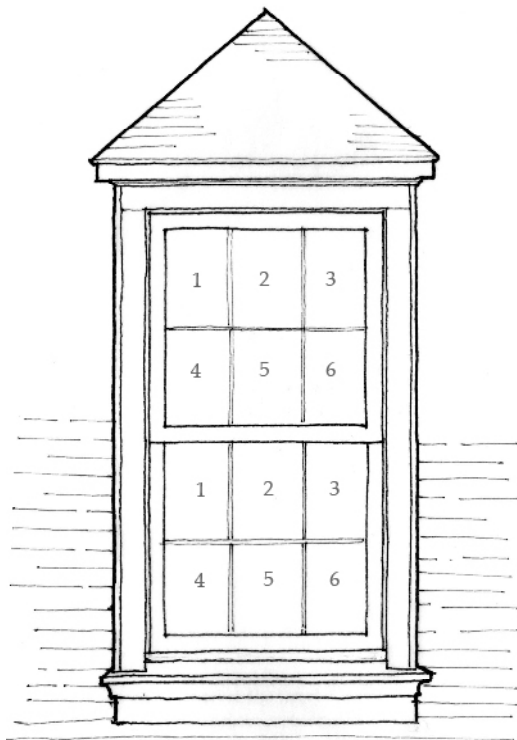

**FRONT ELEVATION**

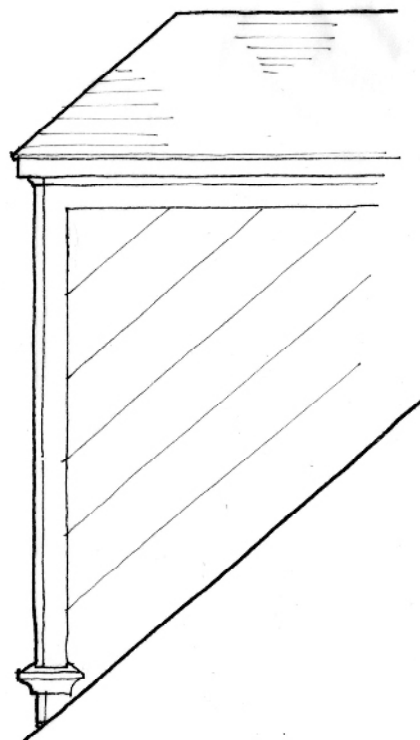

**SIDE ELEVATION**

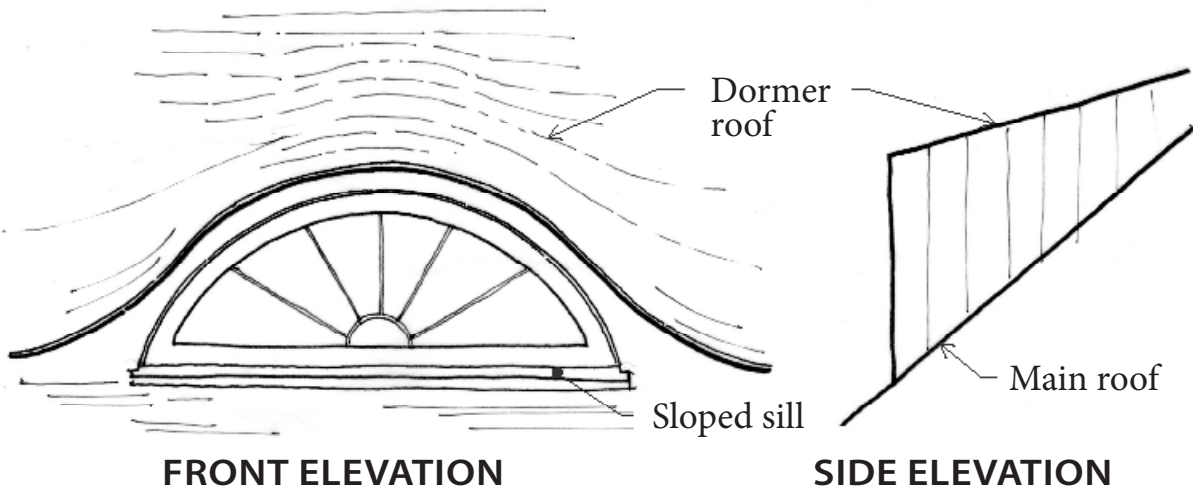
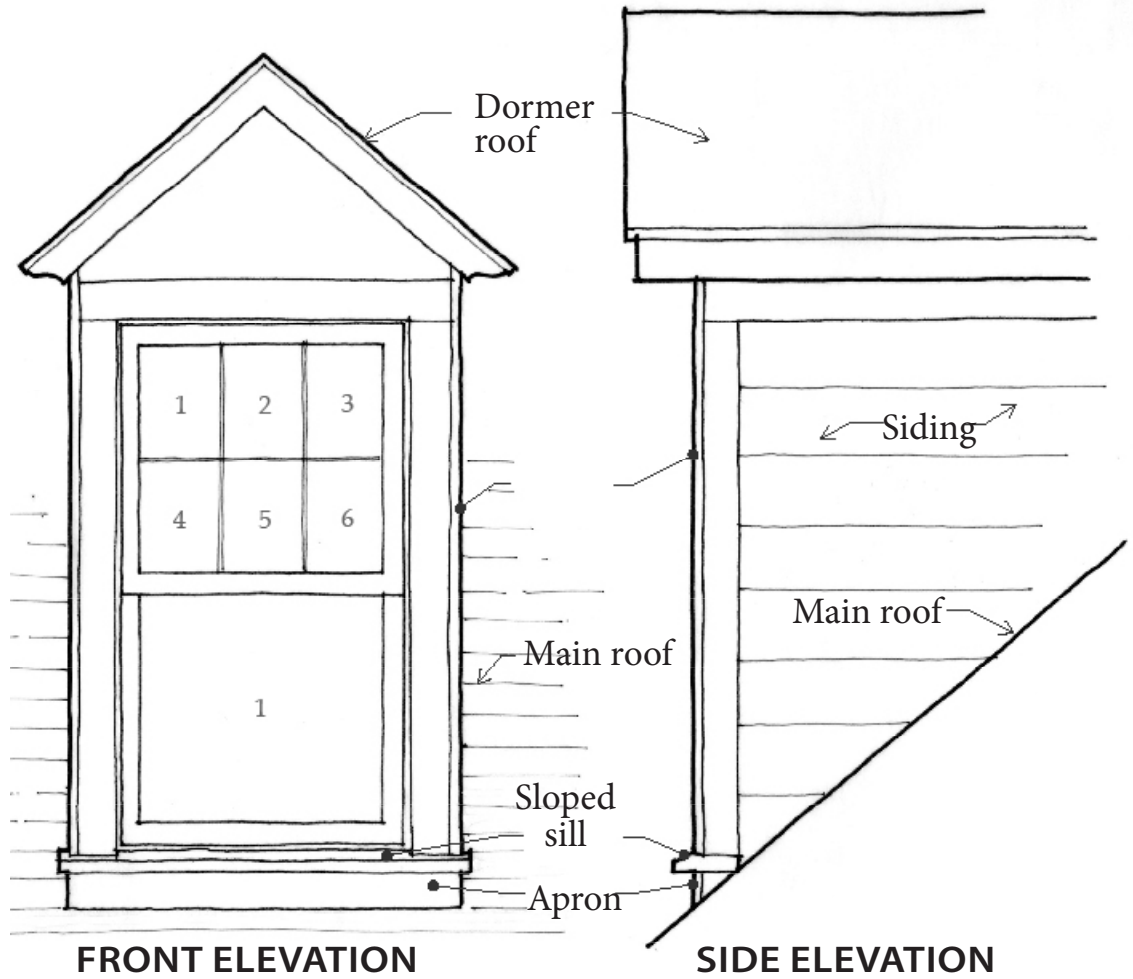

# DORMER TYPES

## GABLE DORMER:

**A gable roof is formed by two sloping sections meeting at the top ridge, forming a triangular shape for the top of window wall of the dormer. The walls of the dormer that extend downward from the gable roof are vertical.**

The dormers ridge line should be below the top of the ridge of the primary roof.

The dormer face, or wall, is set back from the wall below so that it is secondary to the primary roof.

The windows of the dormer should make up most of the front wall, be evenly spaced and match the windows of the primary structure.



## SHED DORMER:

**A dormer having a roof that slopes in the same direction as the roof in which the dormer is located.**

The dormers ridge line should be at or below the top of the ridge of the primary roof.

The dormer face, or wall, is set back from the wall below so that it is secondary to the primary roof.

The windows of the dormer should make up most of the front wall, be evenly spaced and match the windows of the primary structure.

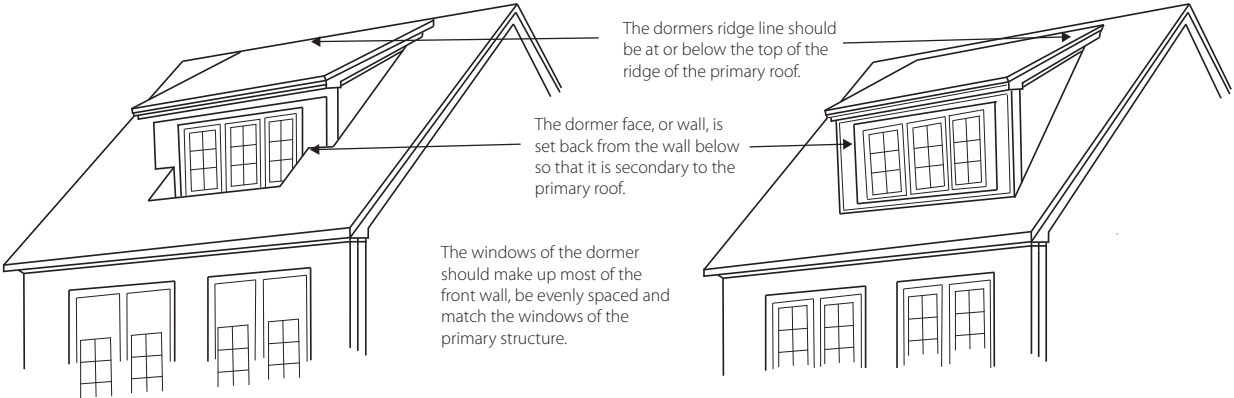

## HIP DORMER:

**A gable roof is formed by two sloping sections meeting at the top ridge, forming a triangular shape for the top of window wall of the dormer. The walls of the dormer that extend downward from the gable roof are vertical.**

The dormer's ridge line should be below the top of the ridge of the primary roof.

The dormer face, or wall, is set back from the wall below so that it is secondary to the primary roof.

The windows of the dormer should make up most of the front wall, be evenly spaced and match the windows of the primary structure.

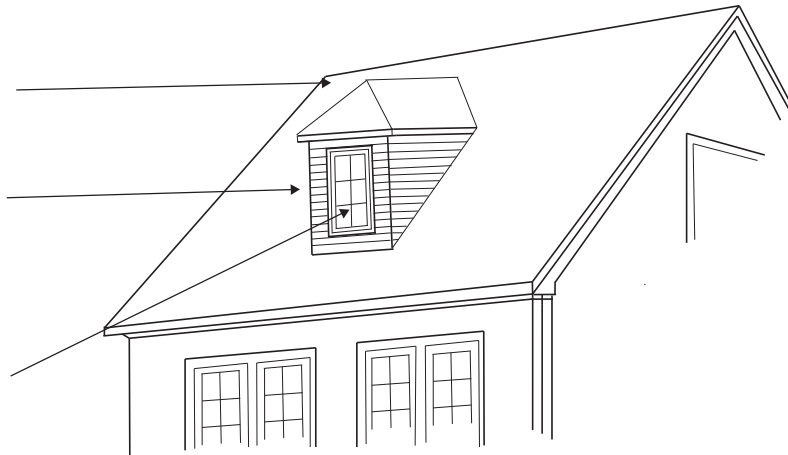

## WALL DORMER:

**A gable roof is formed by two sloping sections meeting at the top ridge, forming a triangular shape for the top of window wall of the dormer. The walls of the dormer that extend downward from the gable roof are vertical.**

The dormer's ridge line should be below the top of the ridge of the primary roof.

The dormer face, or wall, is set back from the wall below so that it is secondary to the primary roof.

The windows of the dormer should make up most of the front wall, be evenly spaced and match the windows of the primary structure.

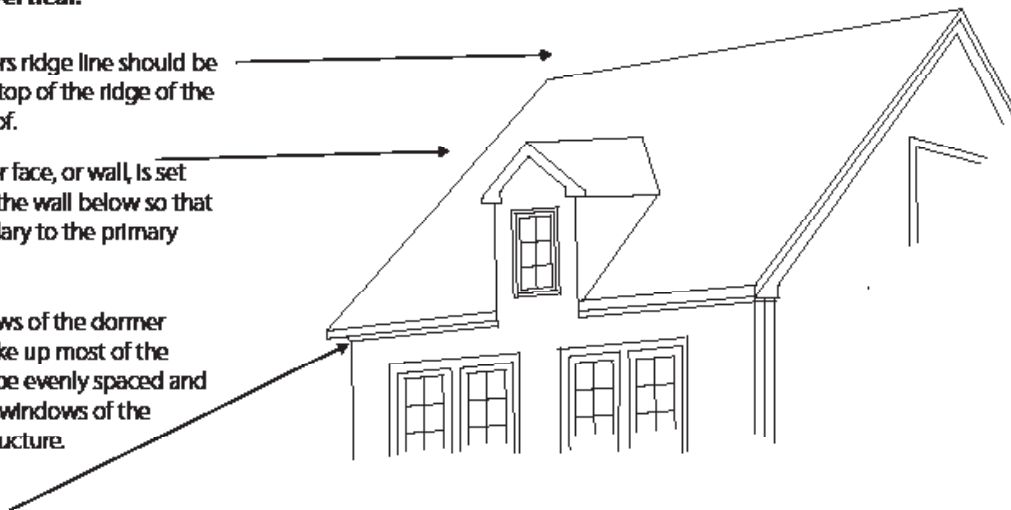

# DORMER DETAILS

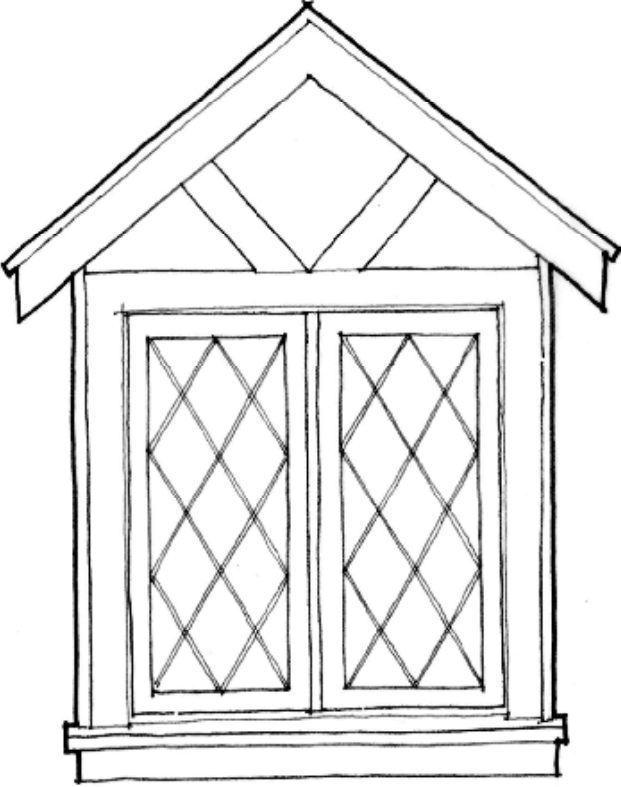
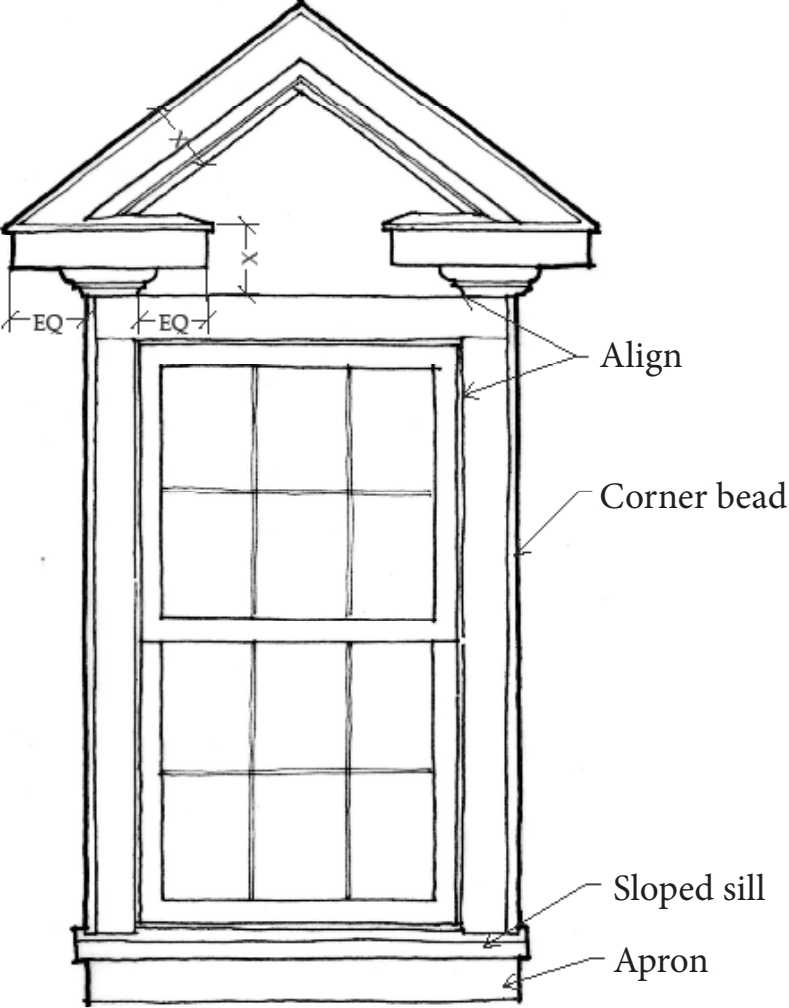

Dormer with casement window and diamond pattern lites - these are historically leaded glass windows.

**DORMER DETAILS TO AVOID**

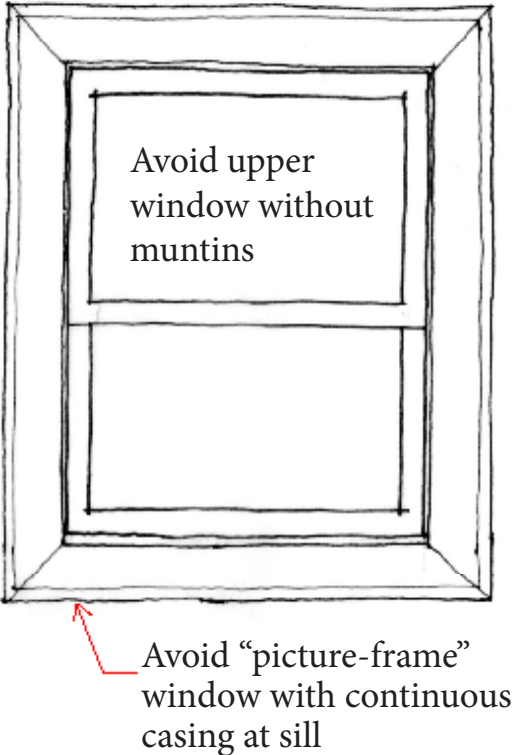
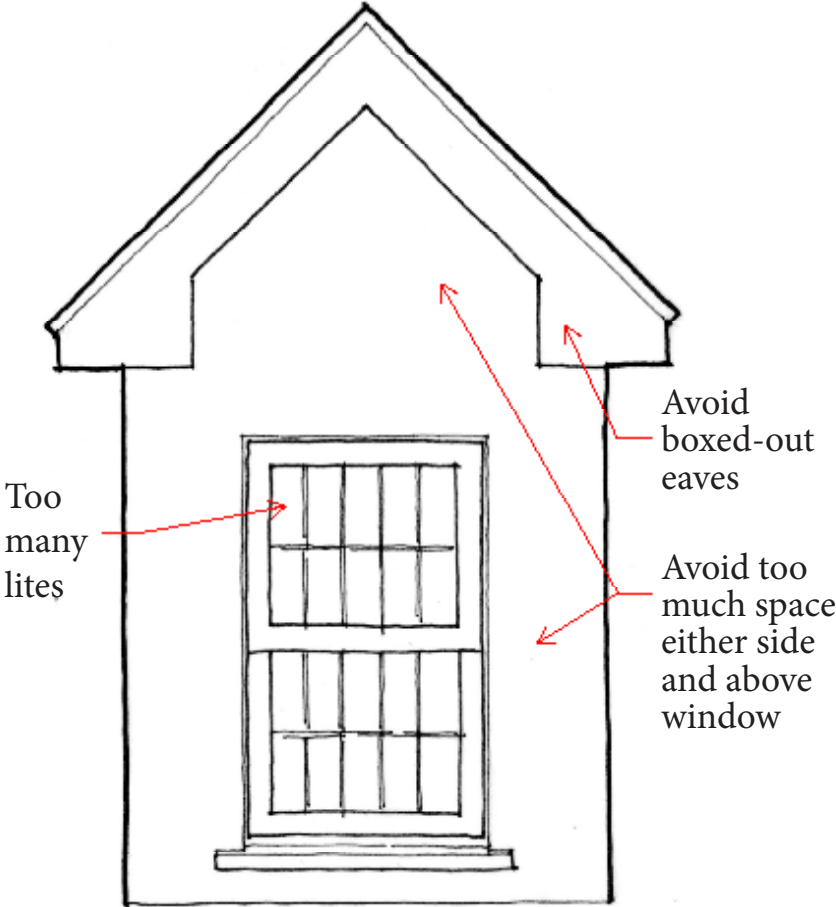



# GARAGES BY LOT SIZE

R-6: Lot Size Less Than 50' x 120'

Max width of detached garage =  
 Max width of other accessory structures =  
 Maximum combined width of all accessory structures =  
 Detached garages shall not be located in front yard.  
 Special Permit needed if detached garage is located in rear yard.

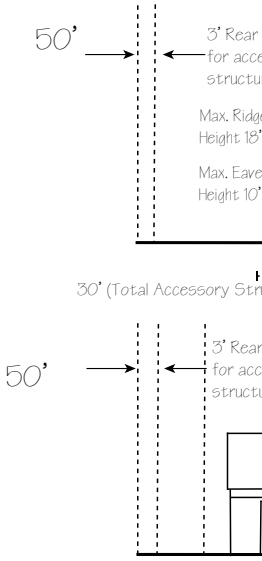
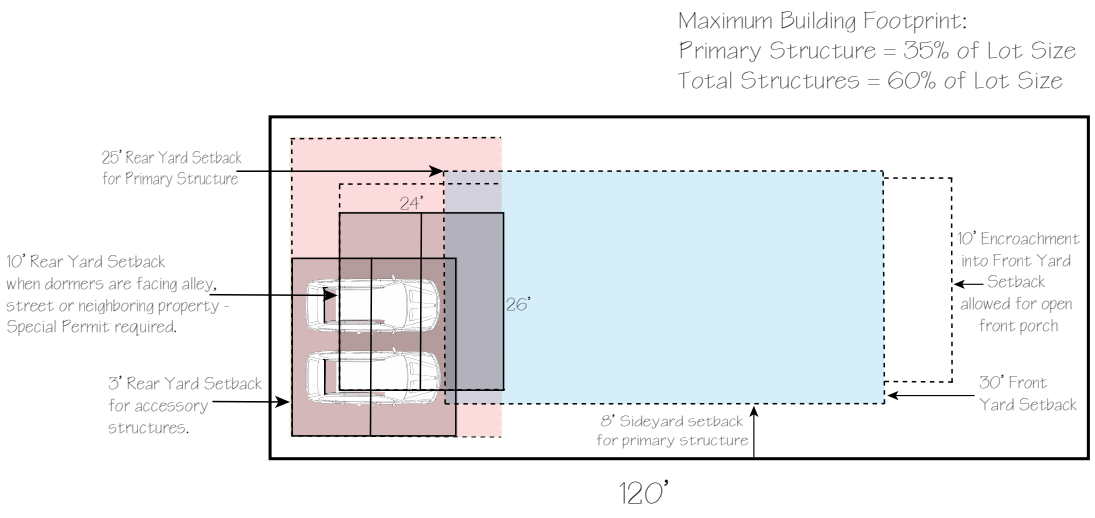

Scale:  
 1/4" = 1' 0"

- Allowable Primary Structure Area
- Allowable Garage Placement Area
- Typical Garage Footprint

Less than 6000 sq ft  
 20' (Typical)

= 60% lot width

structures = 40% lot width

accessory structures shall not exceed 60%

less than 10' from principal structure

farmers are facing alley, street, or neighboring property

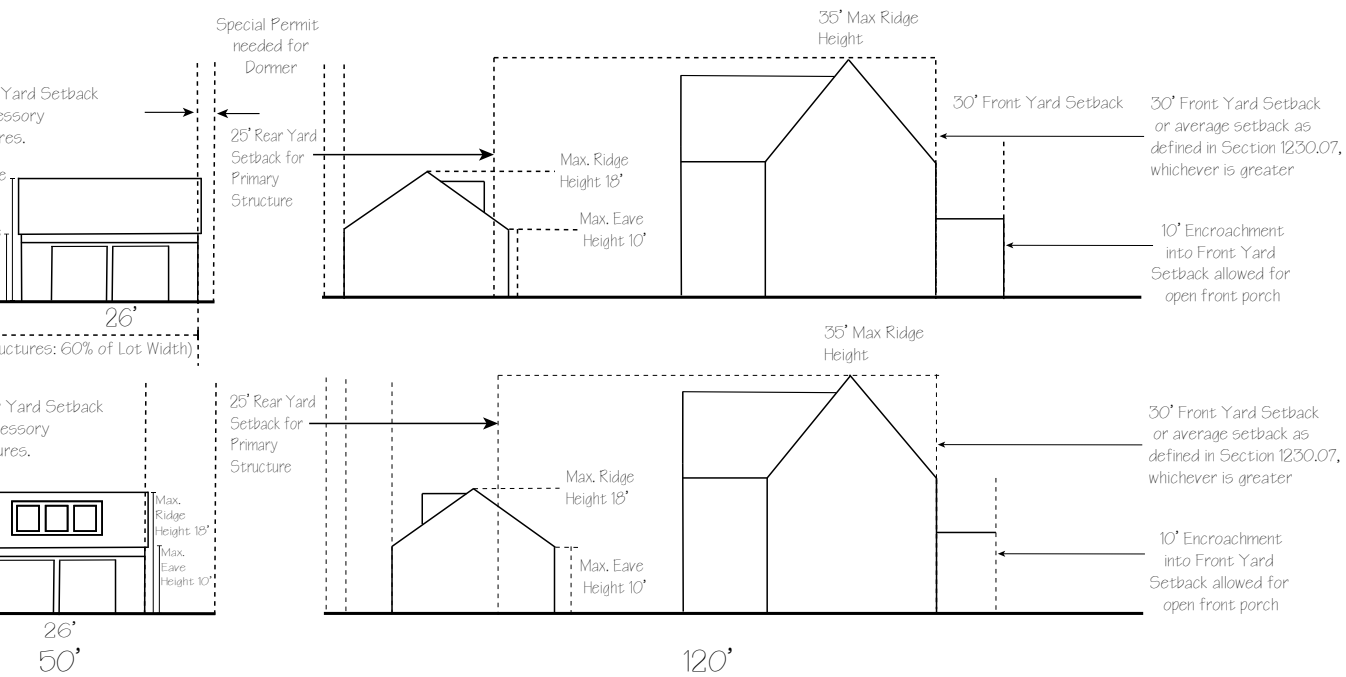

# GARAGES BY LOT SIZE, CONT.

R3: Lot Size 60' x 90'

Max width of detached garage  
 Max width of other accessory structures  
 Maximum combined width of detached garage and other accessory structures  
 Detached garages shall not be located in the front yard  
 Special Permit needed for detached garages

Maximum Building Footprint:  
 Primary Structure = 25% of Lot Size  
 Total Structures = 40% of Lot Size

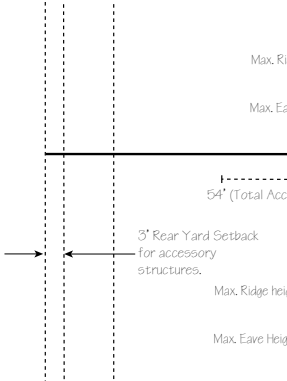
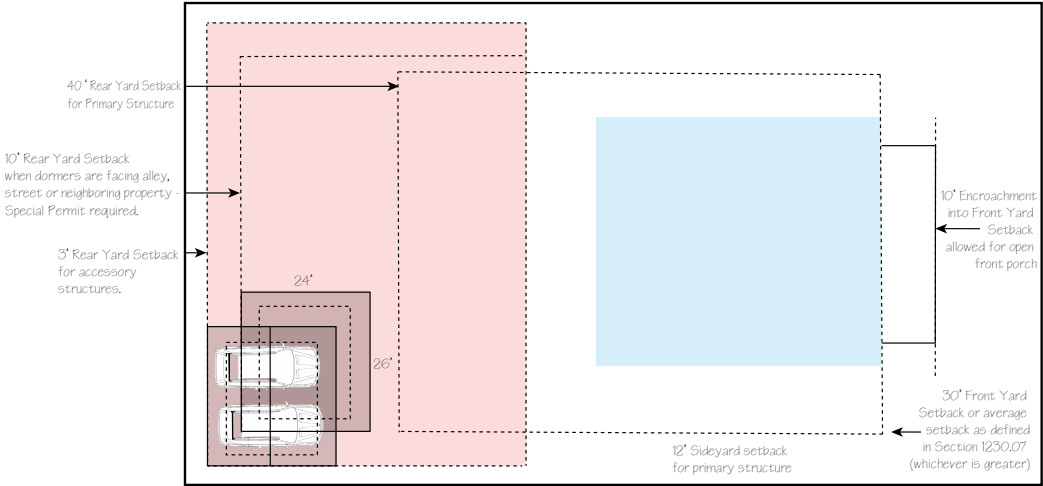

Scale: 1/4" = 1' 0" 160

- Allowable Primary Structure Area
- Allowable Garage Placement Area
- Typical Garage Footprint

6,000 to 13,999 sq ft  
 x 160' (Typical)

and garage = 60% lot width

Accessory structures = 40% lot width

Height of all accessory structures shall not exceed 60%

and shall not be less than 10' from principal structure

unless permitted if dormers are facing alley, street, or neighboring property

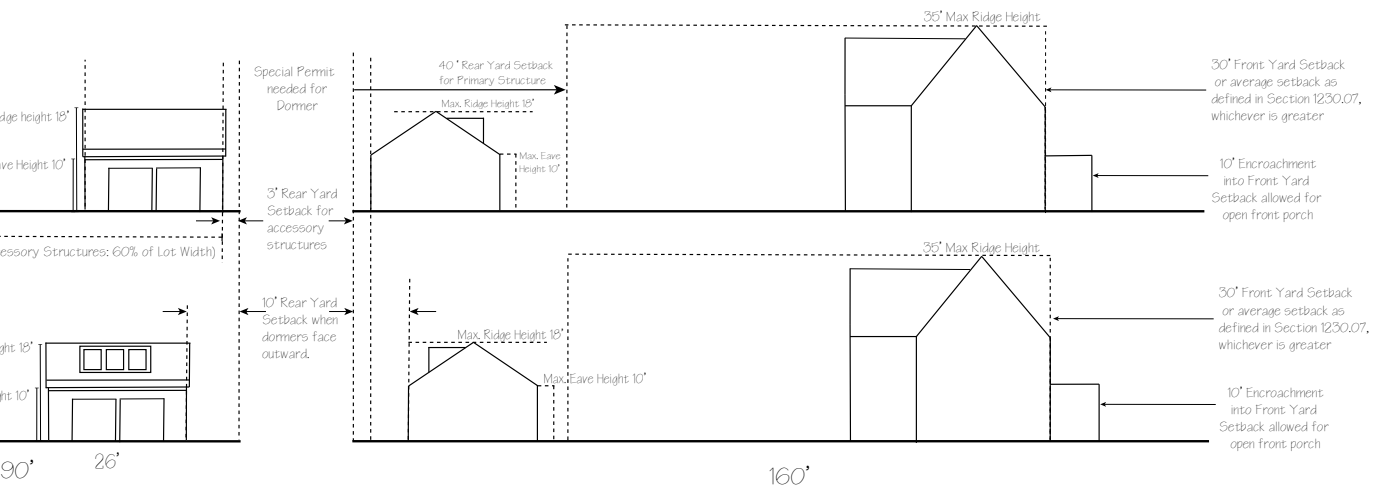

# GARAGES BY LOT SIZE, CONT.

R2: Lot Size

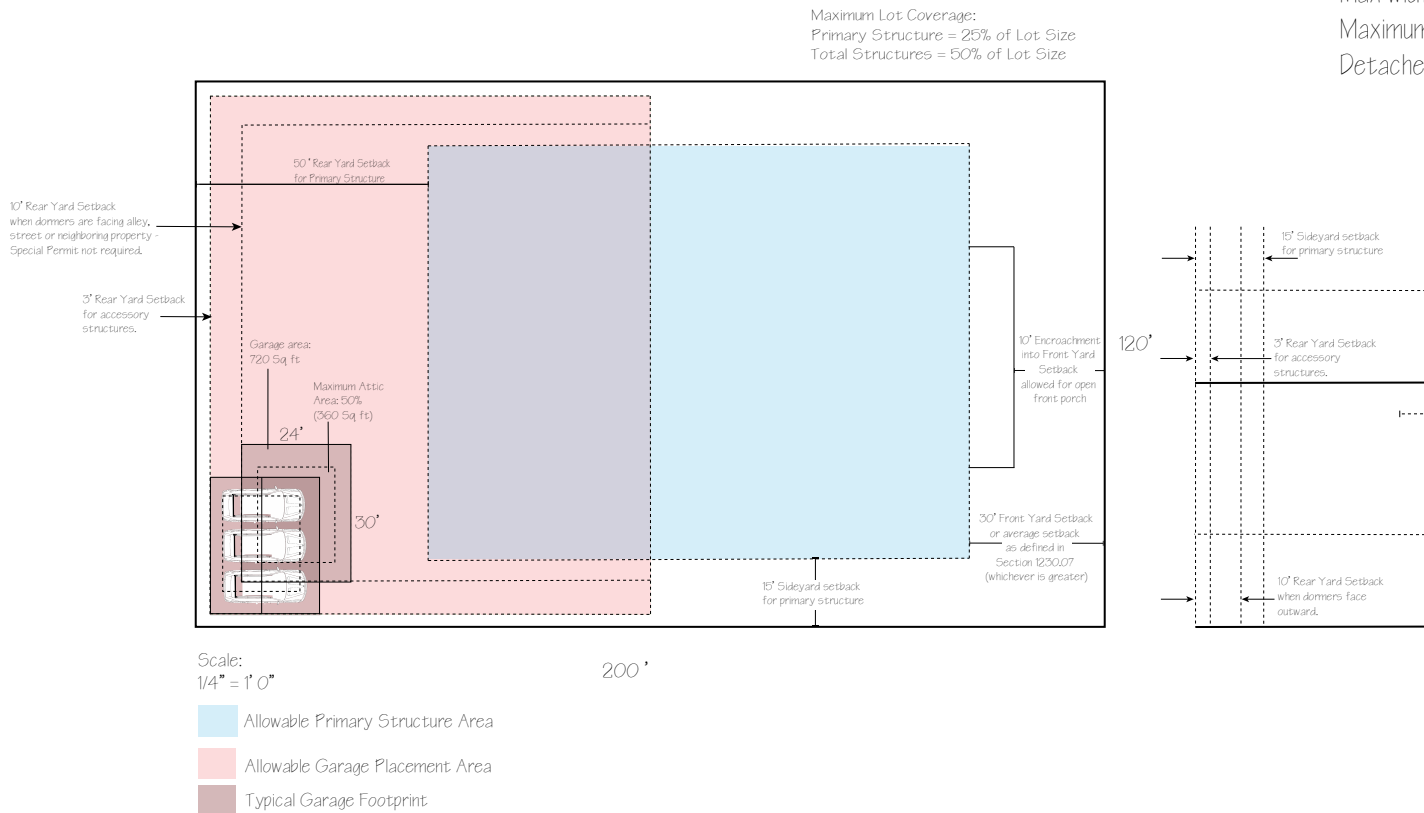

14,400 - 23,999 sq ft or greater  
 120' x 200' (Typical)

Width of detached garage = 60% lot width  
 Width of other accessory structures = 40% lot width  
 The combined width of all accessory structures shall not exceed 60%  
 Detached garages shall not be less than 10' from principal structure

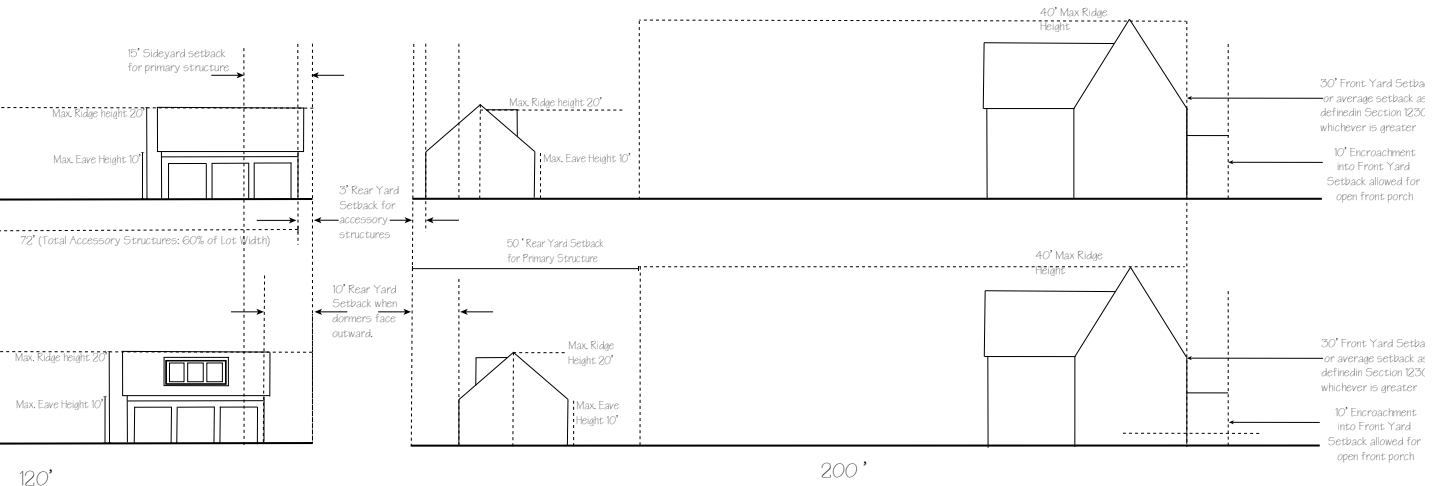

# GARAGES BY LOT SIZE, CONT.

R1: Lot Size 2  
150

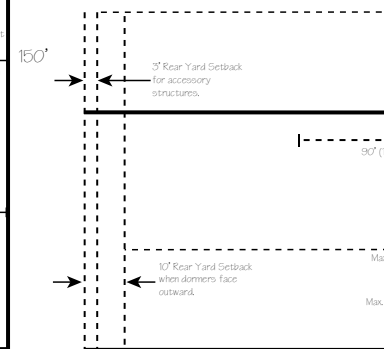
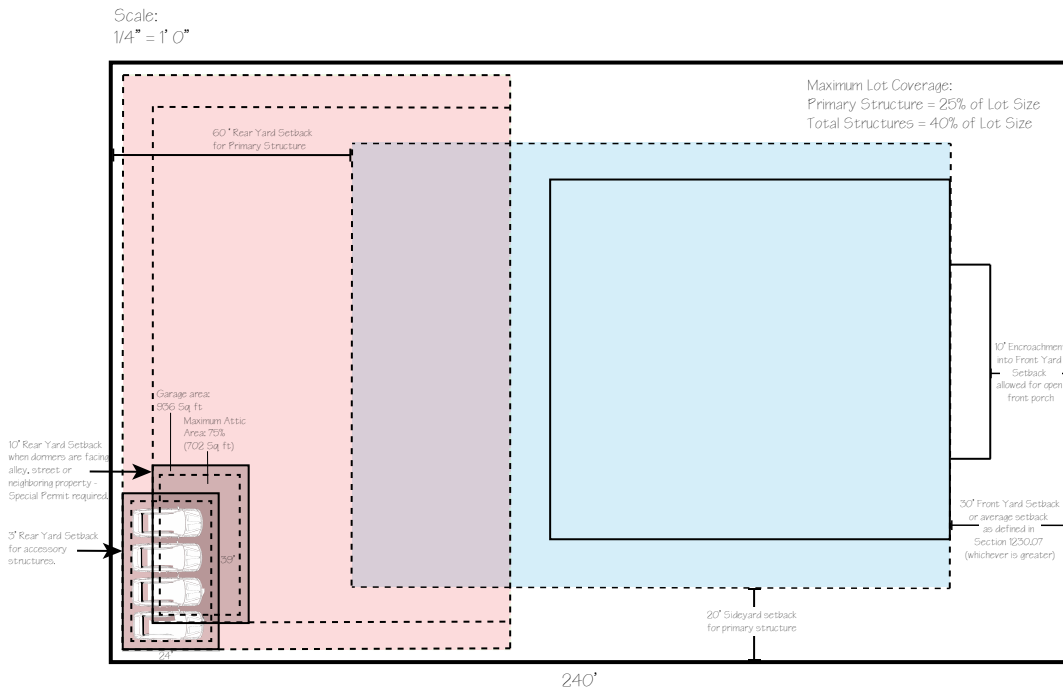

Scale:  
1/4" = 1' 0"

- Allowable Primary Structure Area
- Allowable Garage Placement Area
- Typical Garage Footprint

24,000 sq ft or greater  
 150' x 240' (Typical)

Max width of detached garage = 60% lot width  
 Max width of other accessory structures = 40% lot width  
 Maximum combined width of all accessory structures shall not exceed 60%  
 Detached garages shall not be less than 10' from principal structure

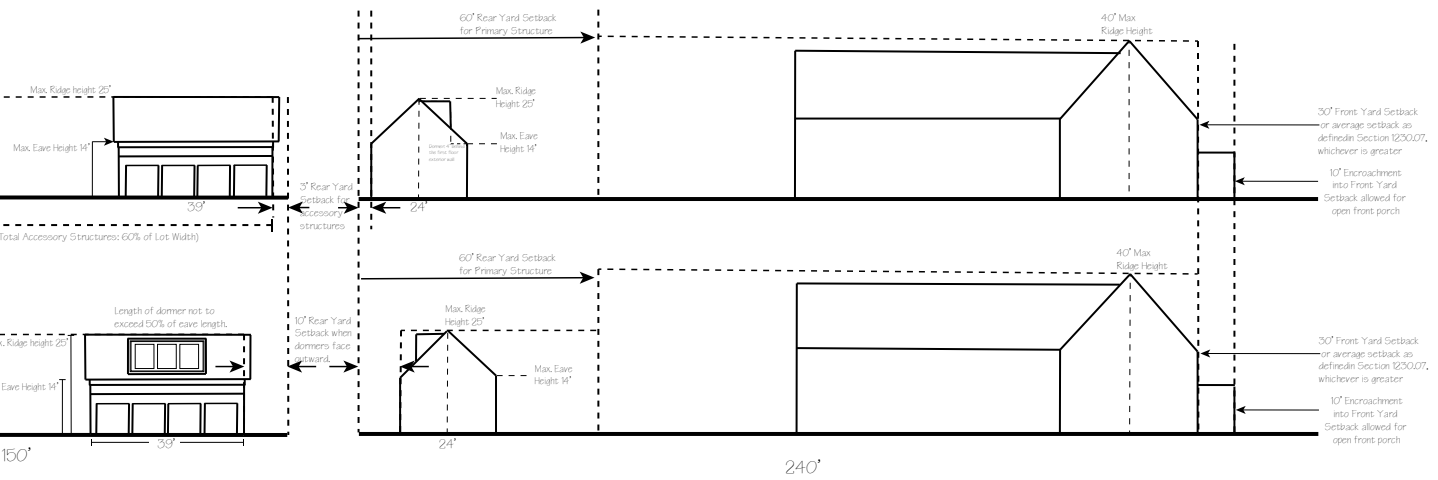



# NEW BUILDING SITE CONSIDERATIONS

FENCING CONSIDERATIONS

LIGHTING CONSIDERATIONS

PARKING CONSIDERATIONS

LANDSCAPING

# SUSTAINABILITY

**MATERIAL CHOICES, ETC....**

**RESPECT/INTERACTION WITH THE ENVIRONMENT (TREE COMMISSION , ARBORETUM...)**

**LIFE CYCLE ANALYSIS (ASTM STANDARD) ANALYSIS OF HISTORICAL WINDOWS**

**RESTORATIVE ENVIRONMENTAL DESIGN STANDARDS (SEE QUOTES AT END OF THIS DOC)**





# SUSTAINABILITY, CONT.

## **SOLAR PANELS** *(THIS SECTION INCLUDES PENDING ORDINANCE CHANGES BEFORE COUNCIL)*

Roof and flush-mounted solar panels shall be allowed, subject to staff review. Installations should be sensitive to the property, surrounding properties, and neighborhood context.

### Roof Mounted Solar Panels:

1. Rear and side locations are preferred. Any installations on the front roof facade shall be justified by providing an analysis of why the front facade is necessary in order to generate viable output.
2. The color of the solar panels and solar panel trim shall be complementary to roof color as determined by staff. For the purpose of this provision, “complimentary” does not mean that staff shall require panel or panel trim colors that are not standard selections that are readily available on the market.
3. The configuration and profile of the assembly shall be complementary to the roof line and roof façade as determined by staff review. Installations should minimize the number of corners, and should avoid complex and/or nonsymmetrical configurations.
4. Wiring and supporting infrastructure should be designed in such a way as to minimize visibility from the right-of-way.
5. Solar panels shall not project vertically above the peak of the roof to which it is attached, or project vertically more than four (4) feet above a flat roof installation.
6. In the event that Solar Panel Design Guidelines are adopted by the Architectural Review Board with approval by City Council, the application must substantially conform to said Solar Panel Design Guidelines.

### Ground Mounted Solar Panels:

1. Ground mounted solar panels exceeding two (2) square feet in area shall be located in a side or rear yard only, with the same setback requirement as accessory structures.
2. Ground mounted solar panels shall not exceed ten (10) feet in height.

### Exemptions:

The following installation types are not subject to the regulations set forth above.

1. Solar panels less than two (2) square feet in area.
2. Solar panels installed within the right-of-way by the City.

# SOLAR PANEL ROOF EXAMPLES

DO use regular patterns with the orientation the same direction.



DO use color choices that will match the details of the existing structure.



DO NOT use color choices that do not compliment the details of the existing structure or mix colors, shapes and sizes of panels.



# HISTORIC PRESERVATION AND DESIGN GUIDELINES FOR REHABILITATION

## GENERAL REHABILITATION ADVICE FROM THE SECRETARY OF THE INTERIOR'S STANDARDS FOR REHABILITATION:

The Standards (Department of Interior regulations, 36 CFR 67) pertain to historic buildings of all materials, construction types, sizes, and occupancy and encompass the exterior and the interior, related landscape features and the building's site and environment as well as attached, adjacent, or related new construction. The Standards are to be applied to specific rehabilitation projects in a reasonable manner, taking into consideration economic and technical feasibility.

These standards are simply for reference and background information and, while highly recommended as a guide for rehabilitation, are not specific to Bexley. They have however been a resource for Bexley's own codified ordinances, Board reviews and staff reviews.

City staff and Board members strongly urge residence to follow the advice of the Secretary of Interior when undertaking a home renovation and/or rehabilitation.

1. A property shall be used for its historic purpose or be placed in a new use that requires minimal change to the defining characteristics of the building and its site and environment.
2. The historic character of a property shall be retained and preserved. The removal of historic materials or alteration of features and spaces that characterize a property shall be avoided.
3. Each property shall be recognized as a physical record of its time, place, and use. Changes that create a false sense of historical development, such as adding conjectural features or architectural elements from other buildings, shall not be undertaken.

## GENERAL REHABILITATION ADVICE FROM THE SECRETARY OF THE INTERIOR'S STANDARDS FOR REHABILITATION, CONT. :

4. Most properties change over time; those changes that have acquired historic significance in their own right shall be retained and preserved.
5. Distinctive features, finishes, and construction techniques or examples of craftsmanship that characterize a property shall be preserved.
6. Deteriorated historic features shall be repaired rather than replaced. Where the severity of deterioration requires replacement of a distinctive feature, the new feature shall match the old in design, color, texture, and other visual qualities and, where possible, materials. Replacement of missing features shall be substantiated by documentary, physical, or pictorial evidence.
7. Chemical or physical treatments, such as sandblasting, that cause damage to historic materials shall not be used. The surface cleaning of structures, if appropriate, shall be undertaken using the gentlest means possible.
8. Significant archeological resources affected by a project shall be protected and preserved. If such resources must be disturbed, mitigation measures shall be undertaken.
9. New additions, exterior alterations, or related new construction shall not destroy historic materials that characterize the property. The new work shall be differentiated from the old and shall be compatible with the massing, size, scale, and architectural features to protect the historic integrity of the property and its environment.
10. New additions and adjacent or related new construction shall be undertaken in such a manner that if removed in the future, the essential form and integrity of the historic property and its environment would be unimpaired.



# HISTORIC PRESERVATION AND DESIGN GUIDELINES FOR REHABILITATION, CONT.

## ROOF REPLACEMENT GUIDELINES:

Roofing materials are important contributing visual elements to the integrity of the building materials. Slate is one of the most aesthetically pleasing and durable of all

Staff must approve shingle color and style. New roofs shall be compatible in color and texture with the architectural style of the house.

Any variation from these standards may require an appearance before the ARB. Additionally, applicants whose projects have been reviewed by staff may request and apply for review and approval by the Board. The staff may also decline to review a project and refer it to the ARB.

Every effort should be made to replace deteriorated slate roofs with new slate and to develop an effective maintenance and repair program for slate roofs that can be retained.

Although slate, cedar shakes, and tile replacement roofs are expensive, the superiority of materials and craftsmanship will give years of continued service. If amortized over the life of the roof, the replacement cost can be very reasonable.

- Slate shingles are an administrative approval for replacement of the existing deteriorated slate roofs and for replacement of non-original asphalt shingle roofs in consultation with staff and in accordance with applicable guidelines.
- All hips and ridges recommended to be capped with galvanized metal ridge roll and not cut shingle tabs. Ridge rolls should extend to the ridge edges (flush with the fascia).
- Any and all necessary venting should be installed on the roof ridges underneath the metal ridge roll.
- All metal ridges, valleys and flashing should match the shingles as closely as possible.

(Below is taken from the National Park Service)

It is indicative at once of the awesome powers of nature which have formed it and the expertise and skill of the craftsman in handshaping and laying it on the roof. Installed properly, slate roofs require relatively little maintenance and will last 60 to 125 years or longer depending on the type of slate employed, roof configuration, and the geographical location of the property. Some slates have been known to last over 200 years. Found on virtually every class of structure, slate roofs are perhaps most often associated with institutional, ecclesiastical, and government buildings, where longevity is an especially important consideration in material choices. In the slate quarrying regions of the country, where supply is abundant, slate was often used on farm and agricultural buildings as well.

Because the pattern, detailing, and craftsmanship of slate roofs are important design elements of historic buildings, they should be repaired rather than replaced whenever possible. The purpose of this Preservation Brief is to assist property owners, architects, preservationists, and building managers in understanding the causes of slate roof failures and undertaking the repair and replacement of slate roofs. Details contributing to the character of historic slate roofs are described and guidance is offered on maintenance and the degree of intervention required at various levels of deterioration.

The relatively large percentage of historic buildings roofed with slate during the late nineteenth and early twentieth centuries means that many slate roofs, and the 60 to 125 year life span of the slates most commonly used, may be nearing the end of their serviceable lives at the end of the twentieth century. Too often, these roofs are being improperly repaired or replaced with alternative roofing materials, to the detriment of the historic integrity and appearance of the structure. Increased knowledge of the characteristics of slate and its detailing and installation on the roof can lead to more sensitive interventions in which original material is preserved and the building's historic character maintained. Every effort

# HISTORIC PRESERVATION AND DESIGN GUIDELINES FOR REHABILITATION, CONT.

## SLATE ROOF REPAIR AND REPLACEMENT:

Any/all proposed repairs to existing roofs require Staff/Administrative or Board approval.

There are 3 categories of roof repair and replacement:

1. Repair with original material
2. Replacement in kind
3. Replacement w non original roof material

The following information must be submitted as part of the application process:

### **Repair Options:**

For slate roofs being repaired, any/all missing, damaged, and deteriorated slate on all main and ancillary roofs should be repaired with new or used slate of same color and profile as existing, in accordance with the Architectural Review Board Design Guidelines and all applicable City Codes and industry standards.

### **Removal and Replacement:**

- A Certificate of Appropriateness granted by the Architectural Review Board for a roof replacement is required prior to the removal of a slate roof.
- Pictures showing all roof surfaces and dominant street views shall be included in the submission.
- Applicants should provide written estimates for slate repair as well as both replacement of the roof with slate and replacement with proposed new replacement material.
- In addition to a written description of the existing condition of the slate, all slate roof assessments should provide the type and style of slate.
- Applicants should address:
  - the remaining life of the existing slate roof
  - the estimated future life of the roof repaired and remaining slate
  - the estimated life expectancy of a non slate replacement roof.

It important to understand the life cycle value/cost of a roof repair/ replacement vs simply present cost.

Applicant should provide a written statement of the architectural importance of the existing slate roof (its prominence on the street, its significance to the architecture/architectural style of the home, etc...)

Applicants are to work with the Design Consultant to determine the additional level of documentation necessary for consideration of a slate roof removal. on secondary elevations. Information should include:

- Existing Conditions:
  - Damage
  - Photographs of flashing, leaks, underlayment, etc..
  
- Roof Maintenance History:
  - Documentation
  - Professionals used and qualifications
  
- Additional helpful information:
  - Is the structure on a primary street?
  - Does the existing roof contribute significantly to the architectural integrity of the design of the building?
  - The applicant should submit a minimum of two written slate roof assessment by a qualified slate roofing contractor regarding the existing condition of the slate roof, and documenting, to the commission's satisfaction, that the slate is beyond its serviceable life.
  - The City of Bexley may also engage a slate roofing contractor to evaluate the condition of the existing roof.
  - When slate removal has been determined to be appropriate/necessary, the maintenance and repair of the slate on the primary elevation(s) will be considered in conjunction with replacing the deteriorated slate
  - Roof Character Analysis and Further Considerations: The applicant must work with the Design Consultant to evaluate and document the following:
    - What is the significance or prominence of the primary elevations of the existing roof?

*(Explanations, processes, Illustrations and guidelines for the following to be added)...*

**COLOR**

**LANDSCAPE FEATURES**

**GUTTERS AND DOWNSPOUTS**

**ADAPTIVE USE**

**COMMERCIAL CORNICES, PARAPETS**

**AWNINGS**

**SIGNAGE**

**STOREFRONTS**

**ACCESS FOR THE DISABLED**

