

NOTE: MASON TO PROVIDE FOOTING  
DESIGN- 20" CMU BLOCK CORE ON  
3'X3"X12" CIC FOOTING AT 36" DEPTH

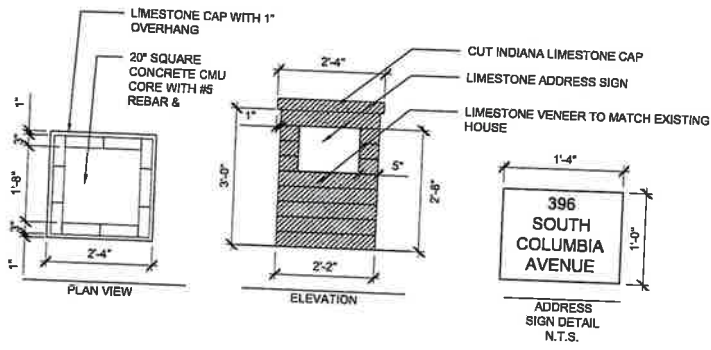

**C** STONE ENTRY COLUMNS  
SCALE: 1/2" = 1'-0"

394 S. Columbia

**SITE INFORMATION**

LOT COVERAGE  
 Total Lot Square Footage: 133,290 = 33,290 SF  
 Allowed Square Footage: 33,290 @ 25% = 8,322.5 SF allowed

Building Coverage  
 Existing primary structure footprint: 10,867 SF  
 Existing pool footprint: 749 SF  
 Existing garage footprint: 749 SF  
 Proposed greenhouse: 150 SF  
 Total proposed building coverage: 12,915 SF

MAXIMUM ACCESSORY BUILDING FOOTPRINT  
 Maximum accessory building footprint is 30% of primary structure footprint:  
 3,260.25% = 11,118 SF allowed

Largest proposed structure is 74.3 SF

MAXIMUM WIDTH OF ACCESSORY STRUCTURES  
 Maximum accessory building width is 40% of lot width:  
 133 x 40% = 53.2 feet allowed

Largest proposed structure is 24.46 feet.

MAXIMUM WIDTH OF ALL ACCESSORY STRUCTURES  
 Maximum accessory building width is 60% of lot width:  
 133 x 60% = 79.8 feet allowed

Accessory Structures  
 Proposed pool (weathered pool): 24.95' x 11.50' (150 SF)  
 Proposed greenhouse: 150 SF  
 Total width of accessory structures: 15.00'

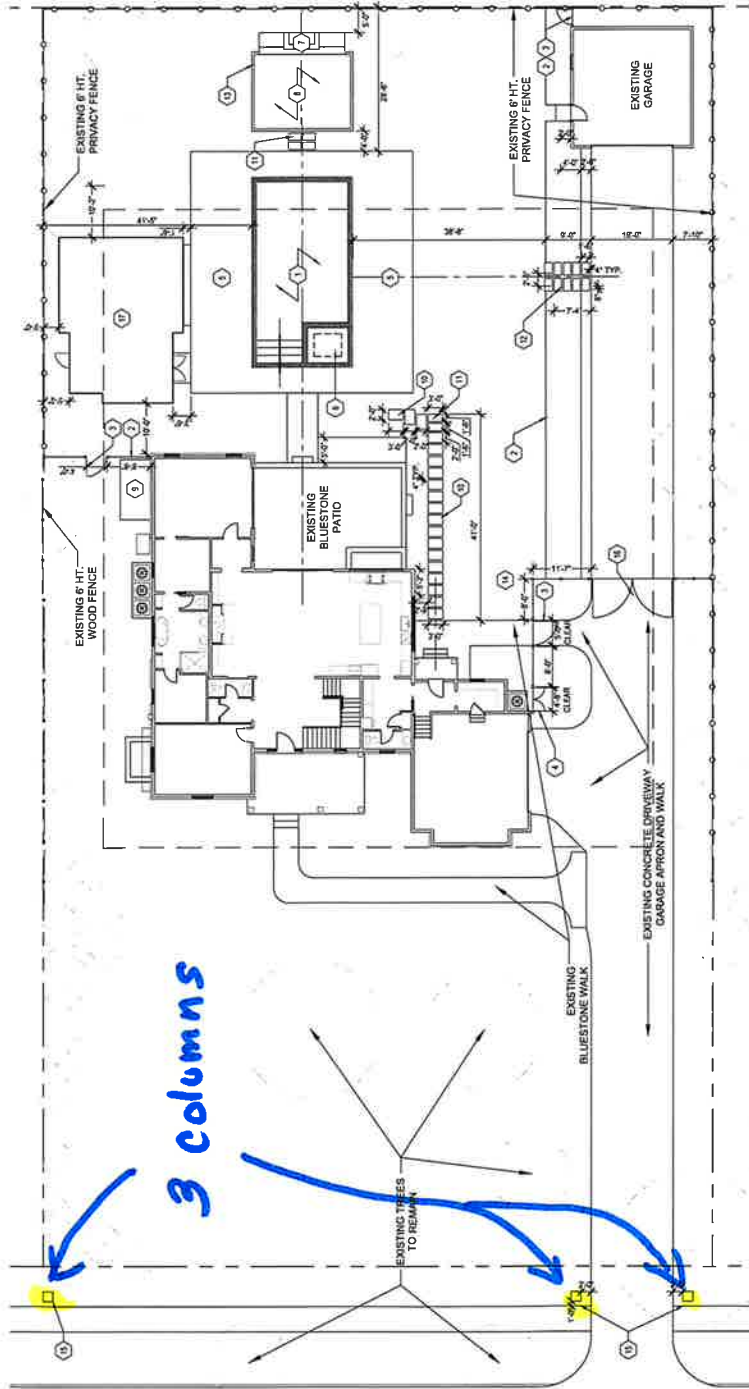

394 S. COLUMBIA AVE.

**LAYOUT PLAN**  
 SCALE: 1" = 10'-0"

**CODED NOTES**

- 1 POOL WITH LIMESTONE COPING
- 2 4" X 4" ALUMINUM POOL PICKET FENCE
- 3 ALUMINUM POOL POCKET FENCE - SINGLE GATE
- 4 ALUMINUM POOL POCKET ALUMINUM POCKET FENCE
- 5 LIMESTONE POOL DECK TO MATCH EXISTING THERMAL (FULL RANGE) LIMESTONE PAVING
- 6 SPA
- 7 OUTDOOR FIREPLACE- SEE DETAIL A.M.P. L1.02
- 8 COMPACTED AGGREGATE TERRACE
- 9 POOL EQUIPMENT
- 10 THERMAL (FULL RANGE) LIMESTONE PAVES STEPPING STONE WALK- 24" X 36" SET IN LAWN WITH TYPICAL 4" JOINT BETWEEN PAVES
- 11 THERMAL (FULL RANGE) LIMESTONE PAVES STEPPING STONE WALK- 18" X 36" SET IN LAWN WITH TYPICAL 4" JOINT BETWEEN PAVES
- 12 THERMAL (FULL RANGE) LIMESTONE PAVES STEPPING STONE WALK- 12" X 36" SET IN LAWN WITH TYPICAL 4" JOINT BETWEEN PAVES
- 13 LIMESTONE CURB EDGE 4" X 24" SET IT FACE. SET CURB EDGE 3" PROUD OF COMPACTED AGGREGATE SURFACE
- 14 FUTURE GREENHOUSE L72007
- 15 STONE ENTRY & ADDRESS COLUMN- SEE DETAIL C1.1.02
- 16 VEHICULAR GATE
- 17 POOL HOUSE

**KEY**

- EXISTING TREE
- EXISTING TREE TO BE SET ASIDE



**SITE PLAN**

NO.	DESCRIPTION	DATE	BY	CHK.
1	PRELIMINARY	10/11/2023		
2	REVISED			
3	REVISED			
4	REVISED			
5	REVISED			
6	REVISED			
7	REVISED			
8	REVISED			
9	REVISED			
10	REVISED			
11	REVISED			
12	REVISED			
13	REVISED			
14	REVISED			
15	REVISED			
16	REVISED			
17	REVISED			
18	REVISED			
19	REVISED			
20	REVISED			
21	REVISED			
22	REVISED			
23	REVISED			
24	REVISED			
25	REVISED			
26	REVISED			
27	REVISED			
28	REVISED			
29	REVISED			
30	REVISED			
31	REVISED			
32	REVISED			
33	REVISED			
34	REVISED			
35	REVISED			
36	REVISED			
37	REVISED			
38	REVISED			
39	REVISED			
40	REVISED			
41	REVISED			
42	REVISED			
43	REVISED			
44	REVISED			
45	REVISED			
46	REVISED			
47	REVISED			
48	REVISED			
49	REVISED			
50	REVISED			

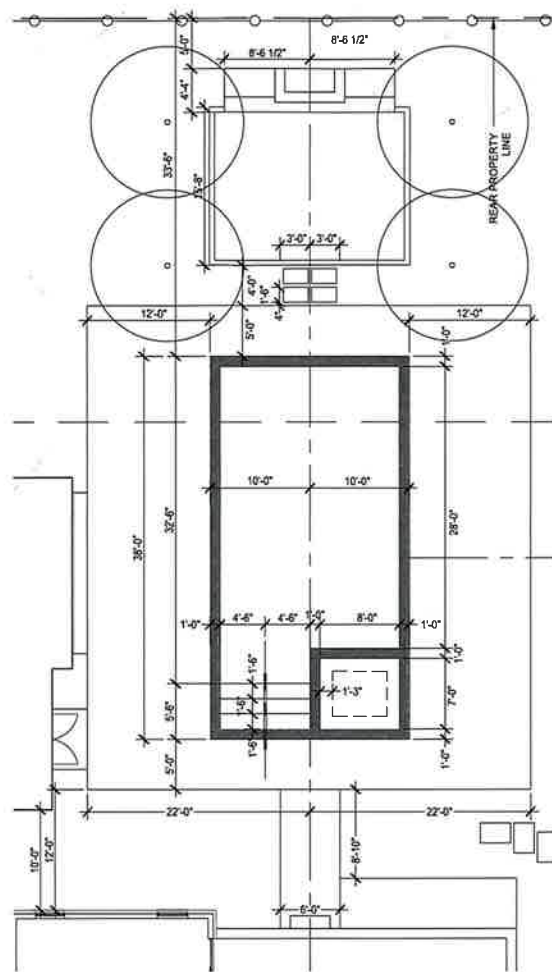

**POOL TERRACES & FIREPLACE LAYOUT**  
 SCALE: 1" = 5'-0"



